

PFAFF

1053

1183

Teilleiste

Parts list

Liste de pièces

Lista de piezas

Alle Informationen und Abbildungen waren zum Zeitpunkt der Druckgebung auf dem neuesten Stand.

Technische Änderungen vorbehalten!

Der Nachdruck, die Vervielfältigung sowie die Übersetzung – auch auszugsweise – aus PFAFF-Teilleisten ist nur mit unserer vorherigen Zustimmung und mit der Quellenangabe gestattet.

At the time of printing, all information and illustrations contained in this document were up to date.

Subject to alteration!

The reprinting, copying or translation of PFAFF parts lists whether in whole or in part, is only permitted with our previous permission and with written reference to the source.

Au moment de la remise à l'imprimeur, toutes les informations et figures se rapportant à cette machine correspondaient à l'état actuel des connaissances.

Sous réserve de modifications techniques!

Aucune reproduction, polycopie ou traduction – même par extraits – listes de pièces PFAFF ne peut être effectuée, à condition d'en indiquer l'origine, sans notre autorisation expresse.

Todas las informaciones e ilustraciones de este manual estaban al día en el momento de entregarse para su impresión.

¡ Salvo modificaciones técnicas!

La reimpresión, reproducción y traducción – aunque sólo sea parcial – de los manuales de instrucciones PFAFF sólo está permitida con nuestro permiso previo e indicando la fuente.

G.M. PFAFF AG
Postfach 3020
D-67653 Kaiserslautern

Redaktion/Illustration
Verlag Technische Dokumentation
Postfach 1106
D-77901 Lahr

	Seite Page Page Página
0	Wichtiger Hinweis 0 - 1 Important note Avis important Observación importante
1	Vorwort 1 - 1 Foreword Avant-propos Notas preliminares
2	Erläuterungen der Schlüsselzeichen 2 - 1 Explanation of key markings Explication des symboles Explicaciones de los signos clave
3	Gehäuseteile 3 - 1 Housing sections Parties du corps Piezas del cárter
4	Kopfteile 4 - 1 Needle head parts Pièces de tête Piezas de la cabeza
5	Armteile 5 - 1 Arm parts Pièces de bras Piezas del brazo
6	Grundplattenteile 6 - 1 Bedplate parts Pièces du plateau fondamental Piezas del cárter
7	Fadenabschneid-Einrichtung Thread trimmer Coupe-fil Cortahilas
7.01	-900/22 7 - 1
7.02	-900/24 7 - 6

8	Fadenabstreif-Einrichtung (-909/04) 8 - 1 Thread wiper (-909/04) Racleur de fil (-909/04) Retirahilos (-909/04)
9	Presserfuß-Automatik (-910/06) 9 - 1 Automatic presser foot lifter (-910/06) Relève-pied automatique (-910/06) Alzaprensatelas (-910/06)
10	Verriegelungs-Einrichtung (-911/37) 10 - 1 Backtacking mechanism (-911/37) Dispositif à points d'arrêt (-911/37) Rematador (-911/37)
11	Anbausatz für externen Motor 11 - 1 Mounting kit for external motor Jeu de pièces pour moteur externe Juego de piezas acoplables para motor externo
12	Anbausatz für integrierten Motor Mounting kit for integrated motor Jeu de pièces pour moteur intégré Juego de piezas acoplables para motor integrado
12.01	Einbaumotor 12 - 1 Built-in motor Moteur incorporé Motor incorporado
12.02	Kabelbaum zum Oberteil 12 - 2 Cable tree to sewing head Faisceau de câbles vers la tête de machine Mazo de cables para el cabezal
12.03	Sollwertgeber 12 - 3 Set-point generator Codeur Emisor del valor teórico
12.04	Steuerkasten 12 - 4 Control box Boîtier de contrôle Caja de mandos
13	Zubehör Accessoires Accessoires Accesorios

13.01	Zubehörteile 13 - 1 Accessoiry parts Accessoires Accesorios
13.02	Knielüfterteile 13 - 2 Knee lifter parts Pièces du releveur de genouillère Piezas del alzaprensateles por rodillera
13.03	Garnrollenständer 13 - 4 Reel stands Porte-bobines Portacarretes
14	Einstellehren 14 - 1 Adjustment gauges Calibres Calibres de ajuste
15	Schmiermittel-Übersicht 15 - 1 Overview of lubricants Tableau de lubrifiants Tabla de lubricantes
16	Keilriemenscheiben-Tabelle (für externen Motor) 16 - 1 Table of V-belt pulleys (for external motor) Tableau des poulies à gorge en V (pour moteur externe) Tabla de poleas para correas en "V" (para motor externo)
17	Index (Teilenummern / Seitenzahlen) 17 - 1 Index (part numbers / page numbers) Index (numéros de pièces, de pages) Index (números de pieza / números de página)
18	Unterklassen-Ausstattung Subclass parts Composition des sous-classes Composición de las subclases
18.01	Unterklassen-Übersicht 18 - 1 Table of subclasses Table de sous-classes Tabla de subclases
18.02	Nähwerkzeuge 18 - 2 Gauge parts Organes de couture Organos de costura

Achtung!



Wir machen ausdrücklich darauf aufmerksam, daß Ersatz- und Zubehörteile, die nicht von uns geliefert werden, auch nicht von uns geprüft und freigegeben sind. Der Einbau und / oder die Verwendung solcher Produkte kann daher u. Umständen konstruktiv vorgegebene Eigenschaften Ihrer Maschine negativ verändern. Für Schäden, die durch die Verwendung von Nicht-Originalteilen entstehen, übernehmen wir keine Haftung!

Caution!



We warn you expressively that spare parts and accessories that are not supplied by us are not tested and released by us. Fitting or using these products may therefore have negative influences on features that depend on the machine design. We are not liable for any damage caused by the use of non-Pfaff parts!

Attention!















Nous attirons expressément votre attention sur le fait que les pièces de rechange et accessoires qui n'ont pas été livrés par nous n'ont pas non plus été contrôlés et agréés par nous. C'est pourquoi le montage et/ou l'utilisation de telles pièces peut éventuellement entraîner l'altération des caractéristiques de construction de votre machine. Par conséquent, nous n'assumons aucune responsabilité pour les dommages causés par l'emploi de pièces qui ne sont pas d'origine!

¡Atención!



Se hace observar que en el caso de piezas de recambio y accesorios que no hayan sido suministrados por nosotros, quiere decir que non han sido sometidas por nuestra parte a un control y que no se les ha dado el visto bueno. Por esta razón, el montaje y/o empleo de tales productos puede repercutir negativamente en las características previstas en su máquina. ¡Para los daños que eventualmente pudiesen presentarse al utilizar piezas no originales, no asumimos ninguna garantía!

- Alle Teile sind so abgebildet, wie sie in der Maschine funktionsmäßig zusammengehören.
 - Gestrichelt dargestellte Teile zeigen angrenzende Teile aus anderen Funktionsgruppen.
 - Im oberen Teil der Bildseiten befindet sich eine Gesamtansicht der Maschine .
Der Einbauort der dargestellten Teile wird durch eine gerasterte Fläche gekennzeichnet.
 - Einrahmungen auf den Bildseiten zeigen, aus welchen Einzelteilen sich die Gruppenteile zusammensetzen.
 - Die auf den Bildseiten verwendeten Schlüsselzeichen ( ;  ;  usw.) sind im Kapitel "Erläuterungen der Schlüsselzeichen" aufgelistet.
-
- All parts are illustrated in function groups with the parts which they function together with in the machine.
 - Parts illustrated with broken lines are parts from other function groups which border on the illustrated function group.
 - The above section of the page of illustrations contains a total view of the machine. The place for the installation of the parts pictured here is marked by the grid.
 - The framed-in sections on the illustration pages show the individual parts comprising a group.
 - The key markings used on the illustrated pages ( ;  ;  etc.) are listed in the chapter "Explanation of key markings".
-
- Toutes les pièces sont représentées en fonction de leur groupement fonctionnel dans la machine.
 - Les pièces hâchurées indiquent les pièces limitrophes de groupes de fonctions différents.
 - La partie supérieure des pages de figures comprend une présentation globale de la machine. L'emplacement des pièces représentées est signalé par quadrillages.
 - Les parties encadrées sur les pages à illustrations représentent les pièces individuelles formant groupe.
 - Vous trouverez au chapitre "Explication des symboles" une liste des symboles utilisés sur les pages de figures ( ;  ;  etc.)
-
- Todas las piezas están ilustradas tal como aparecen en la máquina para su funcionamiento.
 - Las piezas representadas con rayitas muestran piezas colindantes de otros grupos de funciones.
 - En la parte superior de las páginas ilustradas se puede ver una vista en conjunto de la máquina. El lugar de montaje de la pieza representada va caracterizada mediante una superficie reticulada.
 - Los recuadros en las páginas ilustradas indican las piezas individuales de que se componen los grupos.
 - Los signos clave ( ;  ;  etc.) empleados en las páginas con ilustraciones van listados en el capítulo "Explicaciones de los signos clave".

- **Unterklassenabhängig, Teilenummer siehe Unterklassen-Ausstattung**
Subclas-dependent, for part number see subclass parts listing
Fonction de la sous-classe; pour le numéro de la pièce, voir "Equipement de sous-classes"
Dependientes de la subclase, para el número de pieza véase "Dotación de subclases"
- 3** **Geklebt**
Part cemented
Pièce collée
Pieza pegada
- 3/4** **Selbstklebend**
Self-adhesive
Auto-adhésive
Autoadhesivo
- 6** **Nadeldicke und Spitzenform bei Bestellung angeben.**
Needle size and style of point to be stated on order.
Préciser la grosseur de l'aiguille et la forme de la pointe à la commande.
Grosor de aguja y forma de la punta, indíquese en los pedidos.
- 6/3** **Für 1,64 mm Nadeldicke**
For needle thickness of 1.64 mm
Pour grosseur d'aiguille 1,64 mm
Para 1,64 mm de grosor de aguja
- 22** **Zubehör**
Accessories
Accessories
Accesorios
- 27/5** **Eingeklammerte Zahl = Länge in mm.**
Number in brackets = length in mm.
Chiffre entre parenthèses = longueur en mm.
Cifra entre paréntesis = largura en mm.
- 32** **Beim Einbau dieses Teiles wird für die Paßgenauigkeit zum Anschlußteil keine Garantie übernommen; zweckmäßig vollständigem Aggregat bestellen.**
No guarantee is assumed that this part will fit the mating part; it is best to order a complete assembly.
Aucune garantie ne pourra être assurée quant à la précision d'ajustage de cette pièce avec la pièce correspondante; il est indiqué de commander un mécanisme complet.
Al montar esta pieza no se asume garantía alguna en cuanto a la tolerancia y precisión de ajuste respecto a la pieza correspondiente; por esta razón, se recomienda pedir el grupo completo.
- 32/1** **Beim Einbau dieses Teiles ist Nacharbeit erforderlich.**
When fitting this part re-work is required.
Retouches nécessaires au montage.
Al montar esta pieza hay que retocarla antes.

40/3

Fetten mit 280-1-120 247; Bestellnummer siehe Seite 15 - 1.
Grease with 280-1-120 247; for part number see page 15 - 1.
Graisser avec de la graisse 280-1-120 247; n° de commande, voir page 15 - 1.
Engrase con grasa 280-1-120 247; para el número de pedido véase la página 15 - 1.

40/13

Fetten mit 280-1-120 205; Bestellnummer siehe Seite 15 - 1.
Grease with 280-1-120 205; for part number see page 15 - 1.
Graisser avec de la graisse 280-1-120 205; n° de commande, voir page 15 - 1.
Engrase con grasa 280-1-120 205; para el número de pedido véase la página 15 - 1.

40/23

Tränken mit 280-1-120 105; Bestellnummer siehe Seite 15 - 1.
Grease with 280-1-120 105; for part number see page 15 - 1.
Graisser avec de la graisse 280-1-120 105; n° de commande, voir page 15 - 1.
Engrase con grasa 280-1-120 105; para el número de pedido véase la página 15 - 1.

40/24

Ölen mit 280-1-120 105; Bestellnummer siehe Seite 15 - 1.
Oil with 280-1-120 105; for part number see page 15 - 1.
Huiler avec de la graisse 280-1-120 105; n° de commande, voir page 15 - 1.
Lubrifique con grasa 280-1-120 105; para el número de pedido véase la página 15 - 1.

96

Länge angeben.
State length.
Préciser longueur.
Indíquese la largura.

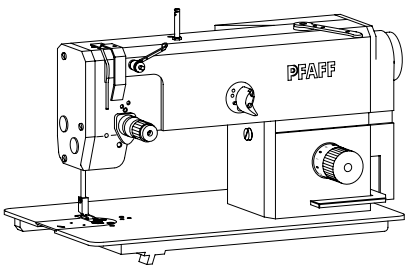

Gehäuseteile
 Housing sections
 Parties du corps
 Piezas del cárter

PFAFF 1053
 PFAFF 1183

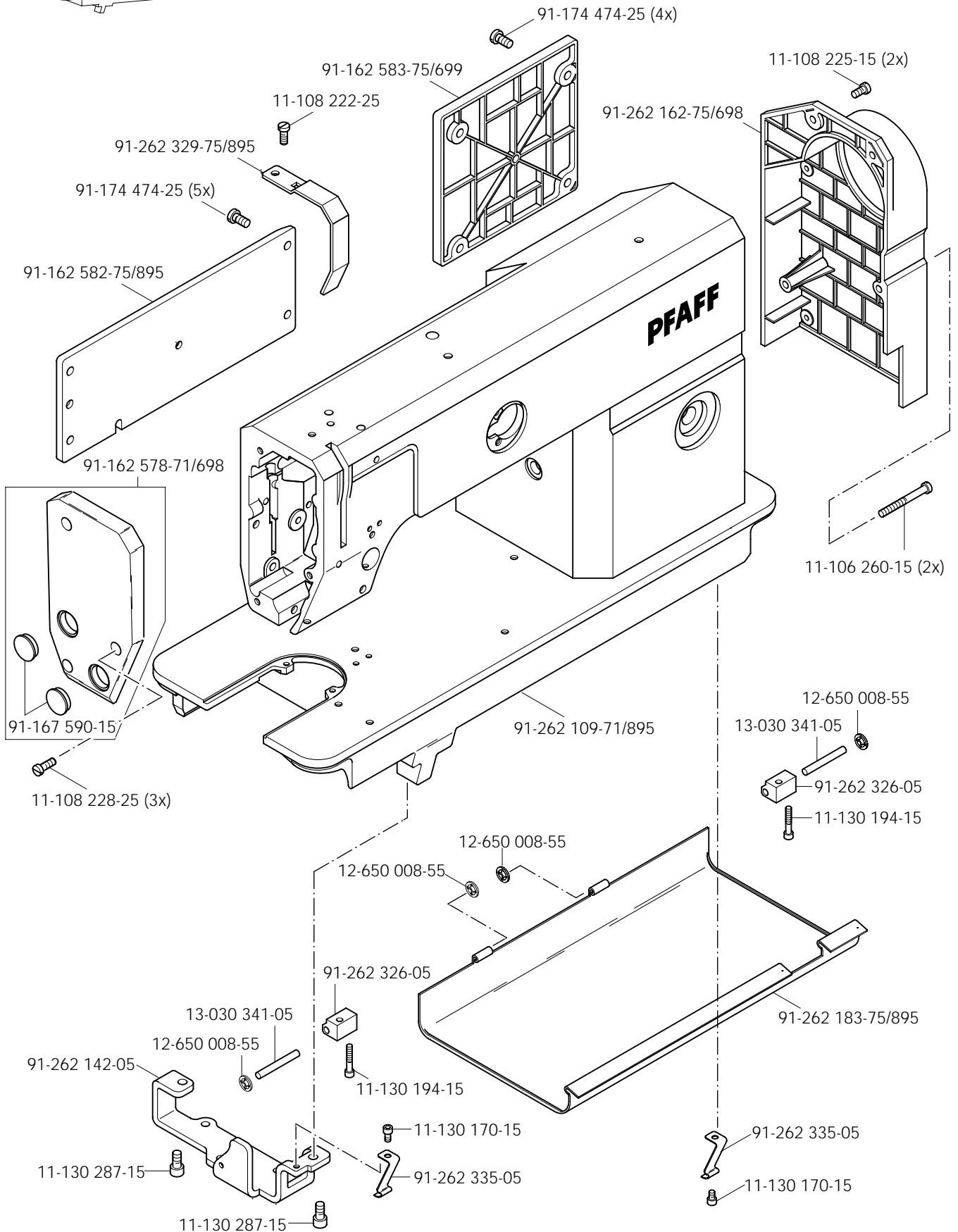

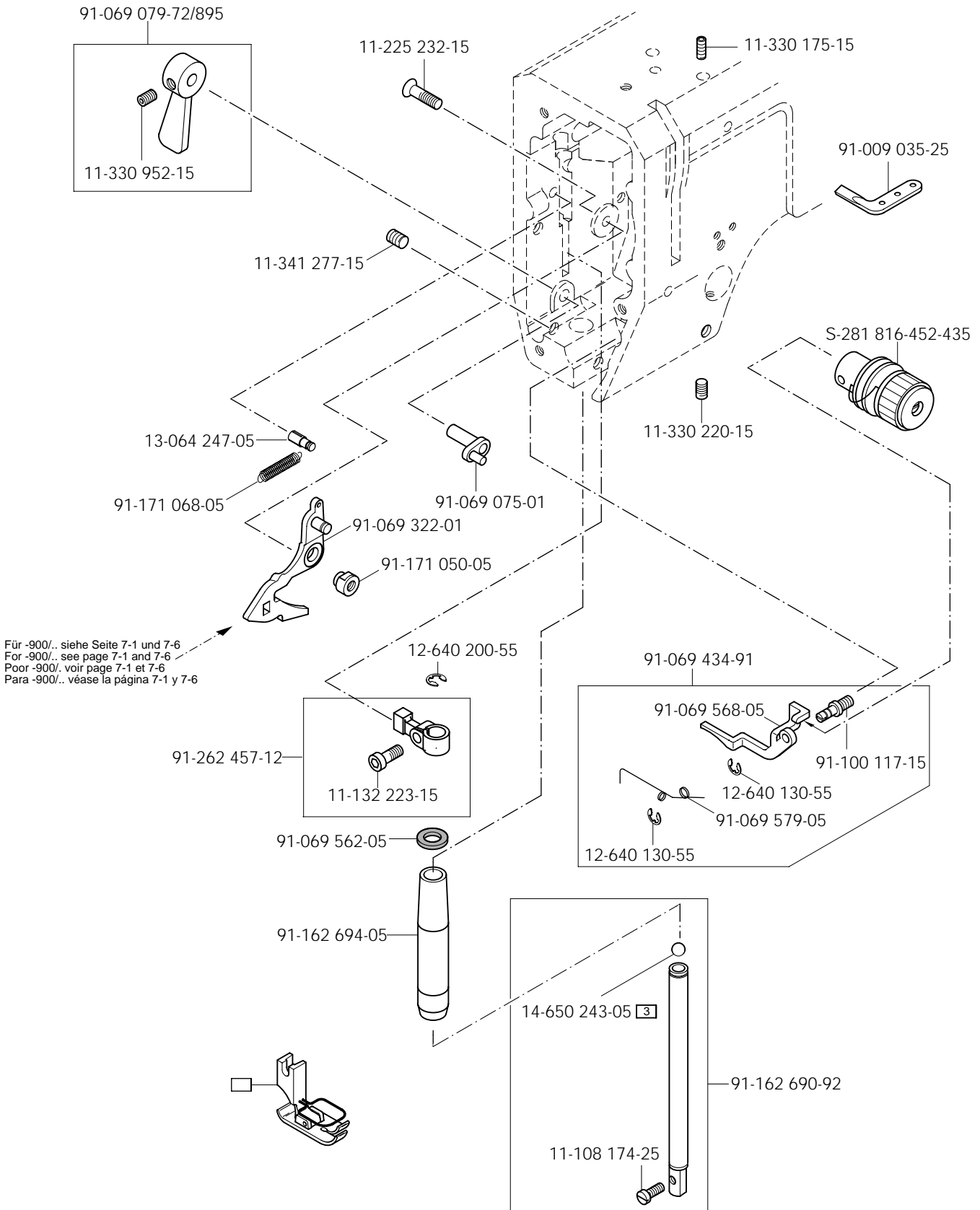
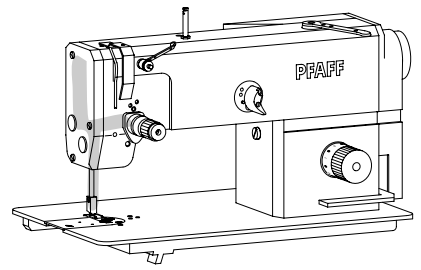

Kopfteile
Needle head parts
Pièces de tête
Piezas de la cabeza PFAFF 1053

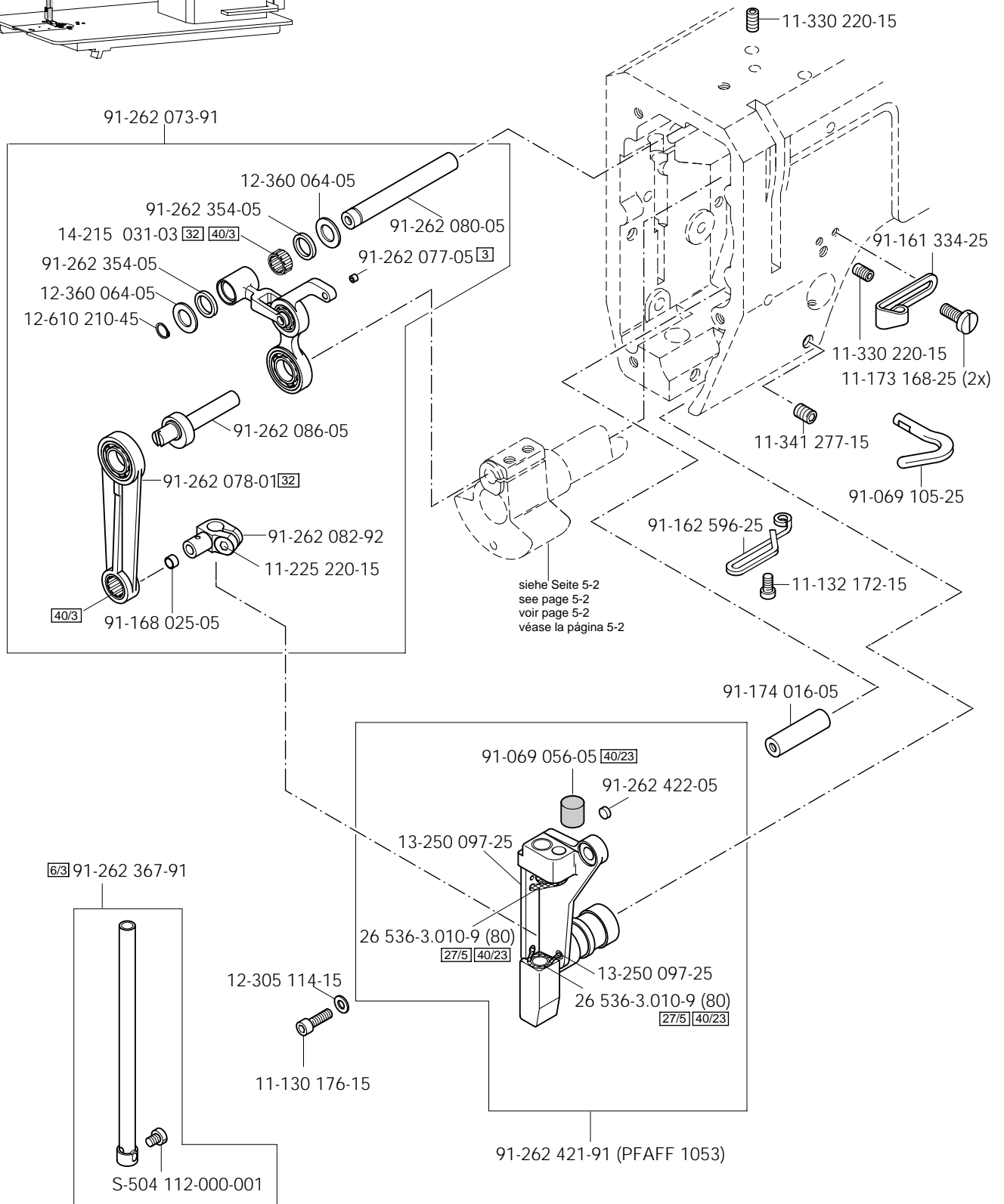
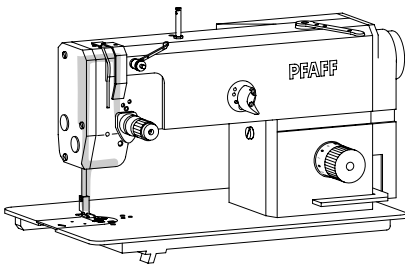

siehe Seite 5-2
see page 5-2
voir page 5-2
véase la página 5-2

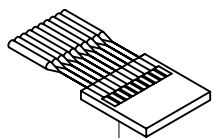

System DBx1 6
Système DBx1 6
Sistema DBx1 6

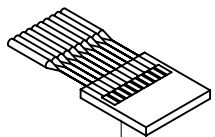
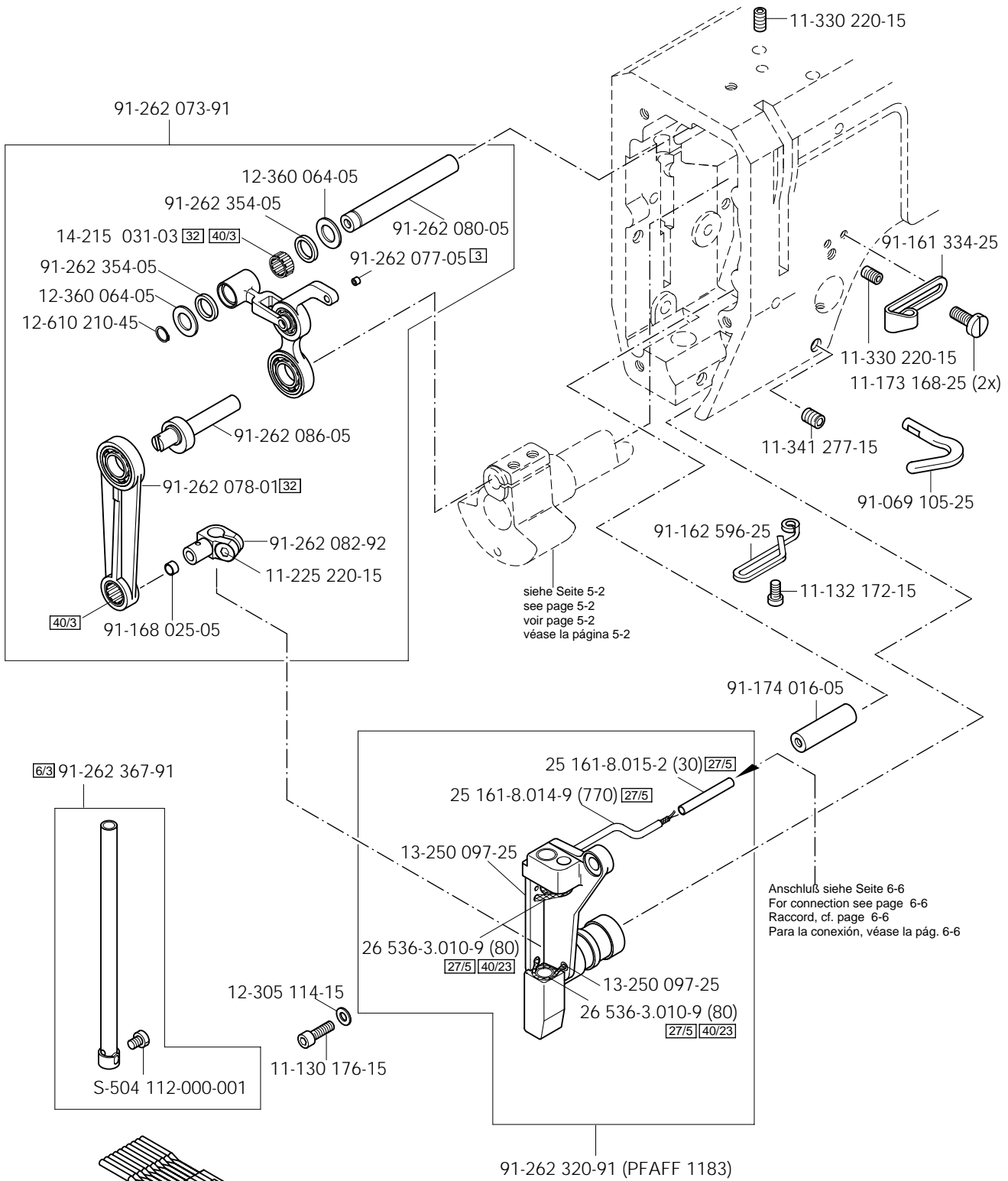
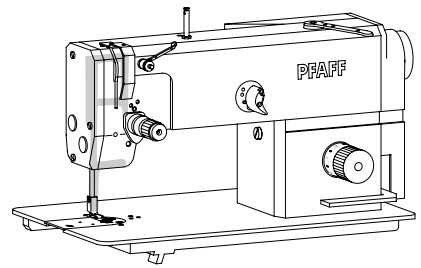

System DBx1 [6]
 Système DBx1 [6]
 Sistema DBx1 [6]

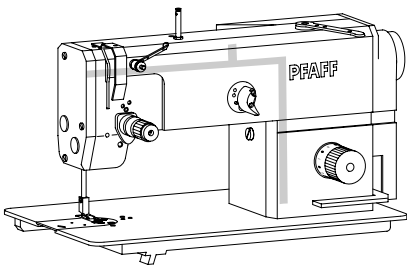

Armteile
 Arm parts
 Pièces de bras PFAFF 1053
 Piezas del brazo PFAFF 1183

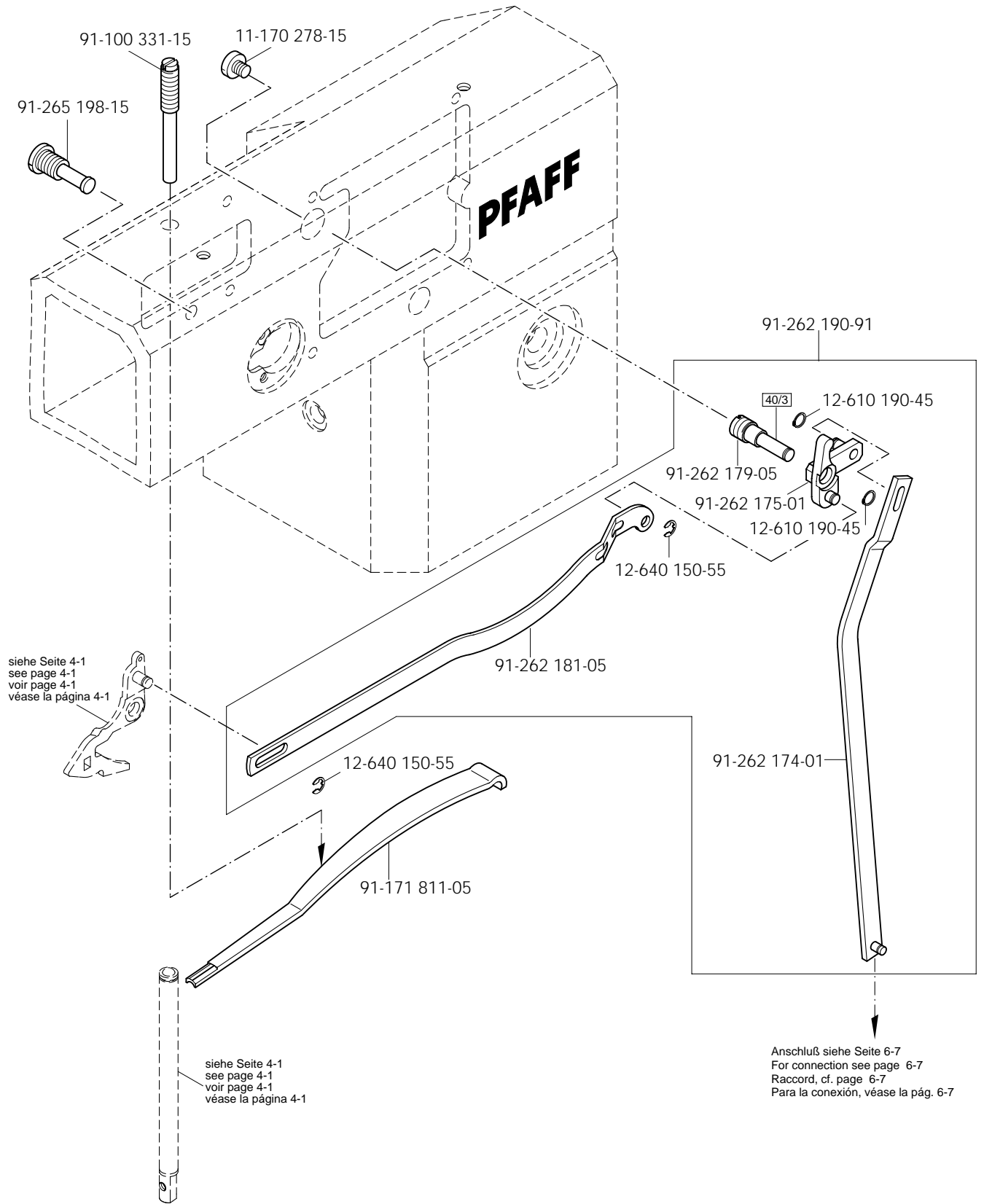

5

Armteile
 Arm parts
 Pièces de bras
 Piezas del brazo

PFAFF 1053
 PFAFF 1183

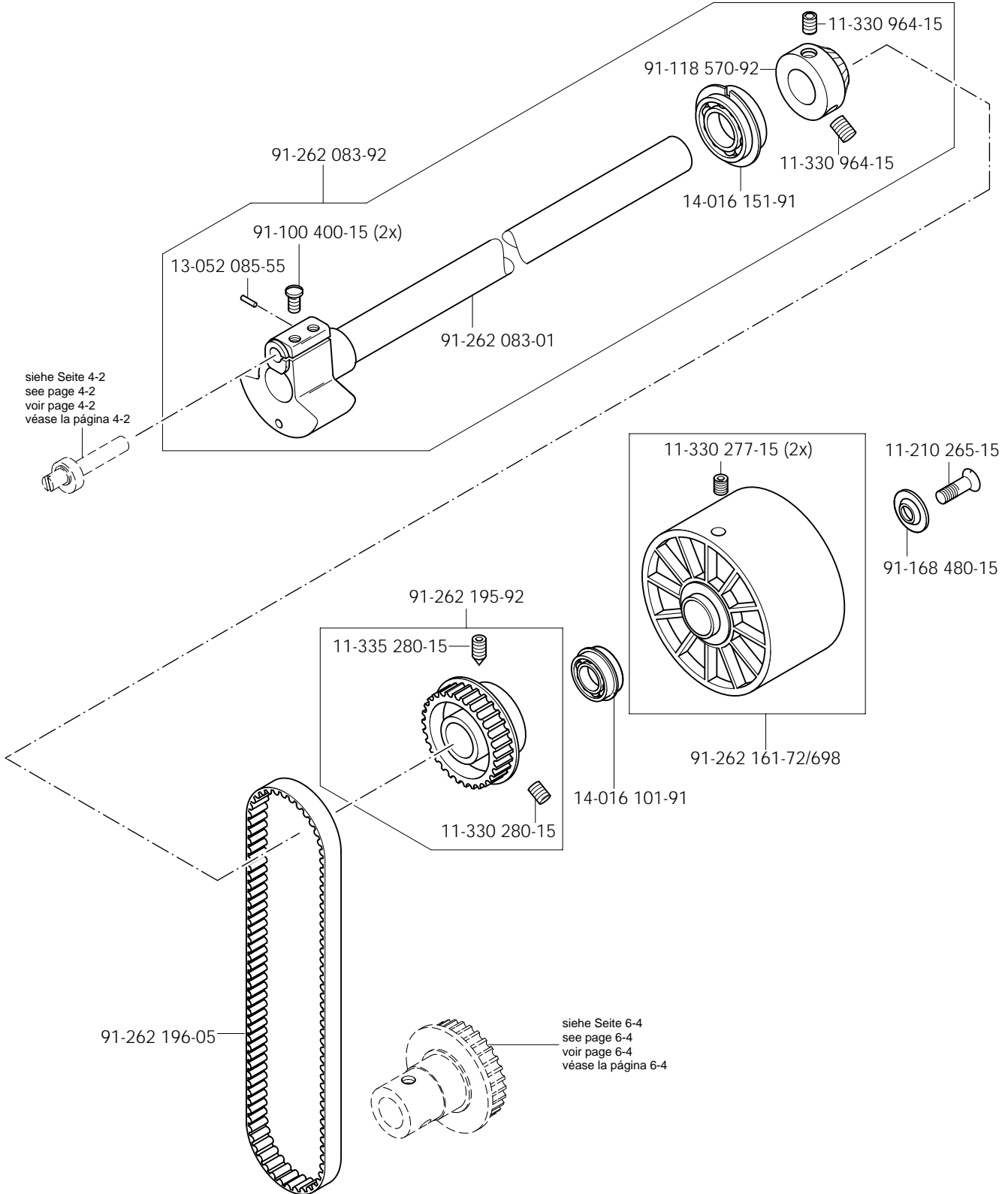
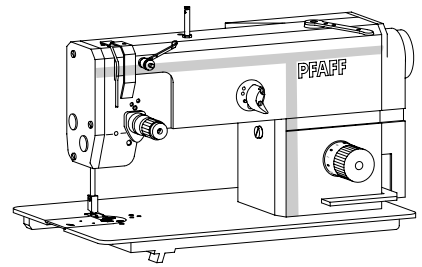

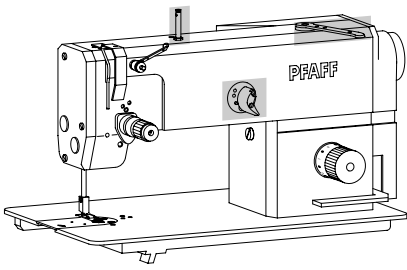

Armteile
 Arm parts
 Pièces de bras PFAFF 1053
 Piezas del brazo PFAFF 1183

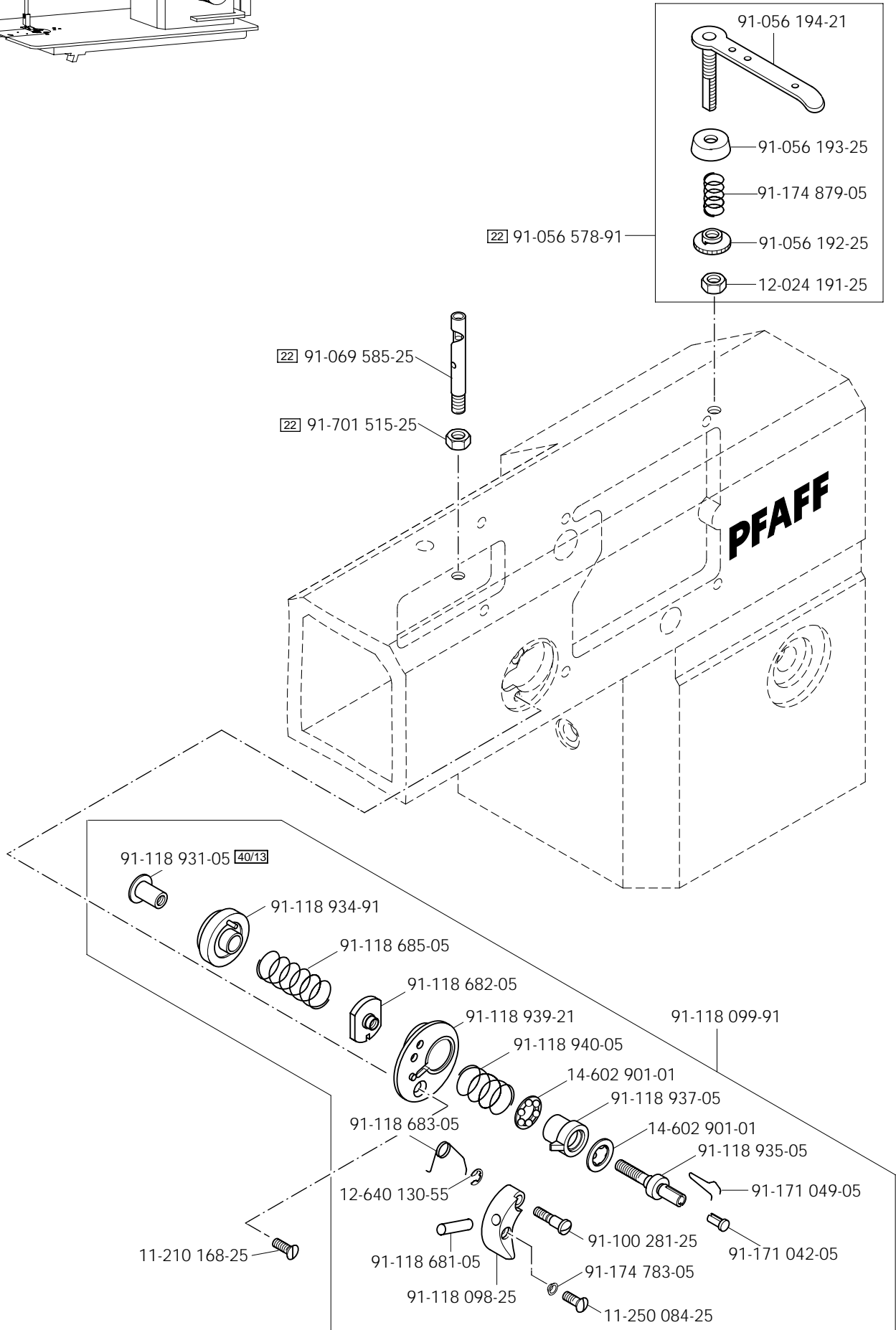

5

Armteile
 Arm parts
 Pièces de bras
 Piezas del brazo

PFAFF 1053
 PFAFF 1183

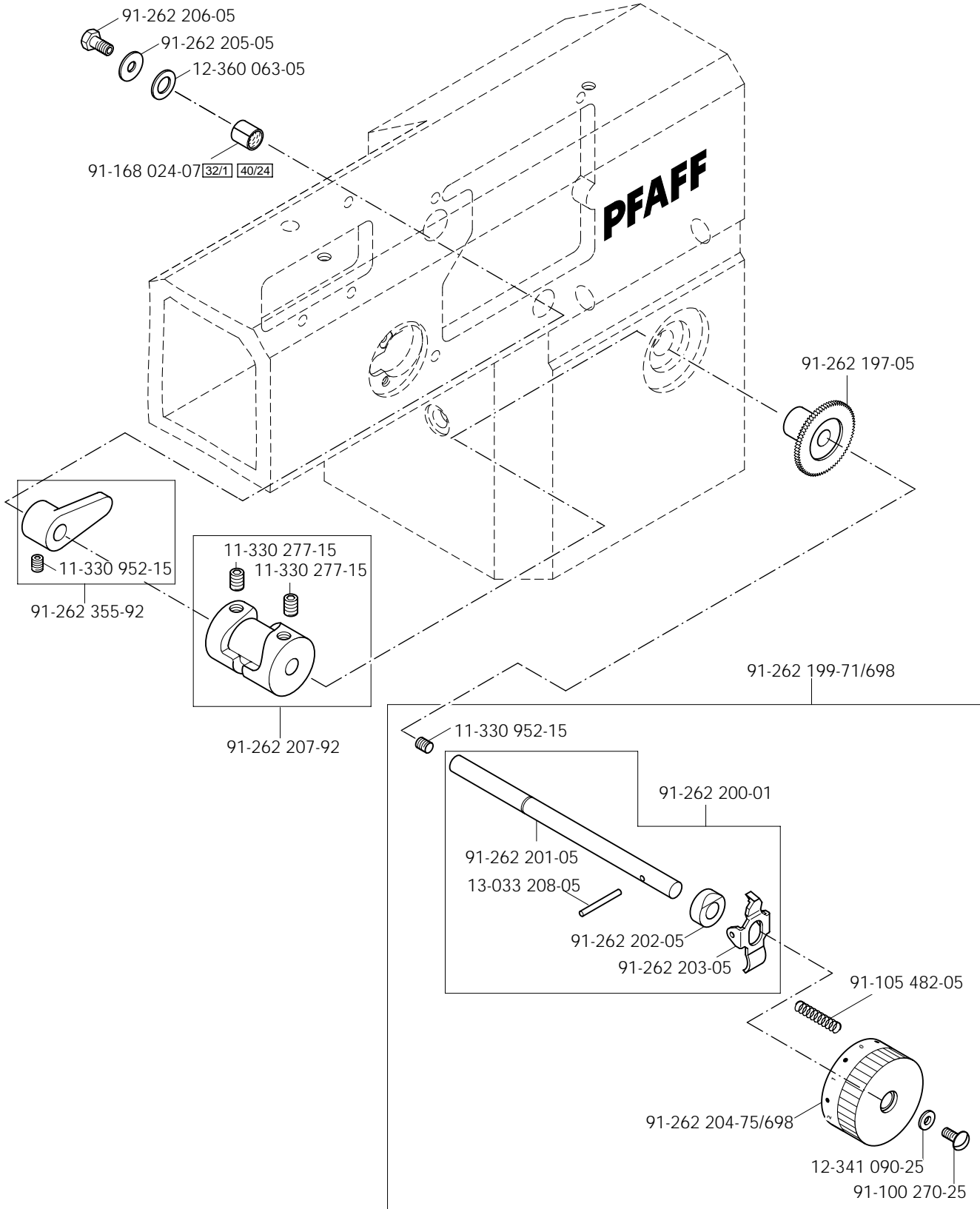
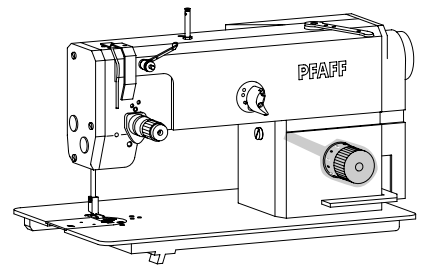

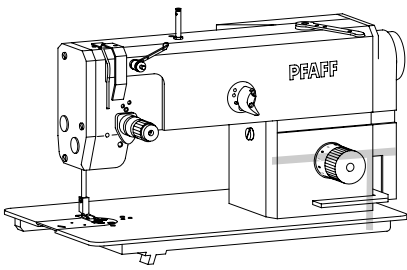

Armteile
 Arm parts
 Pièces de bras PFAFF 1053
 Piezas del brazo PFAFF 1183

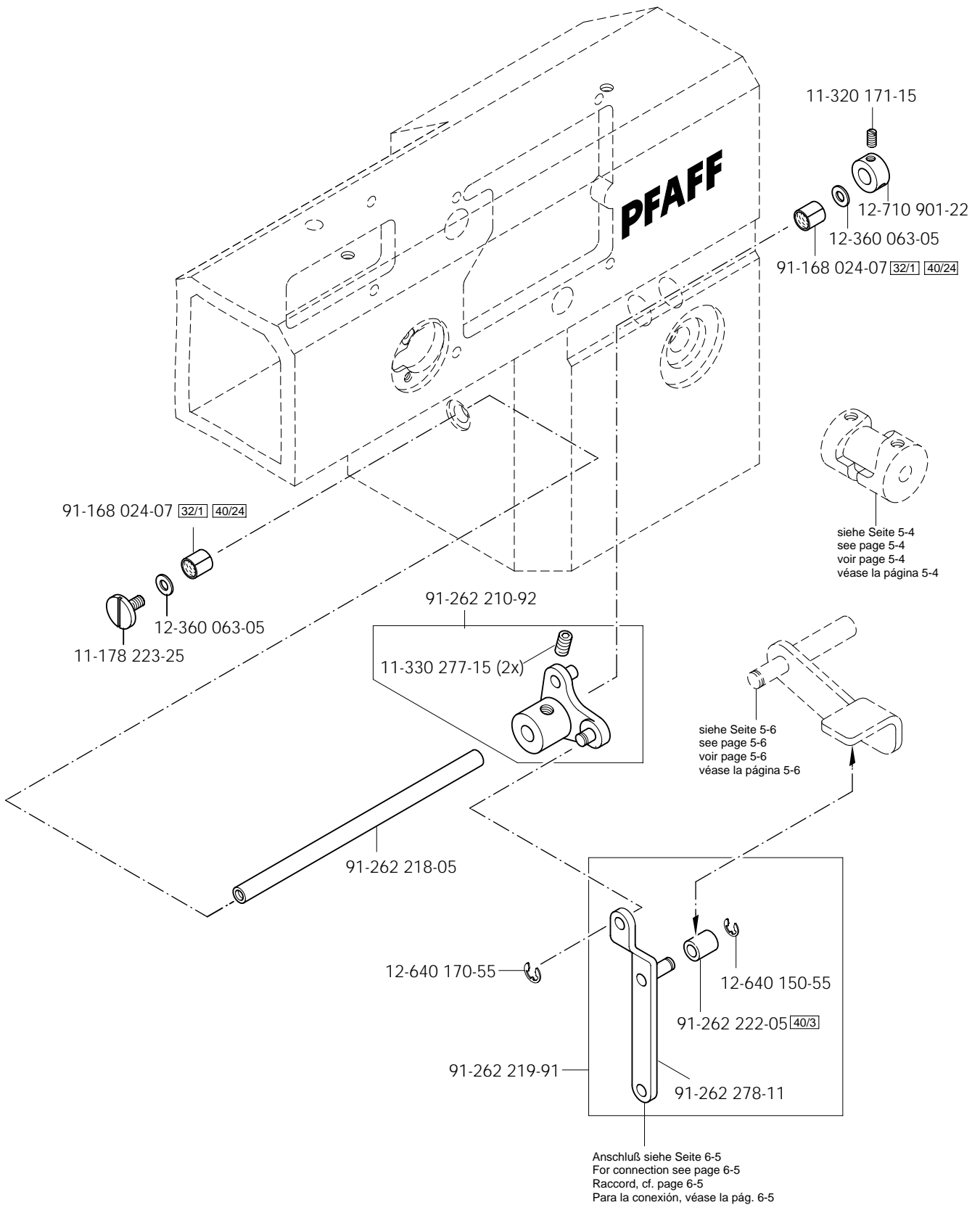

5

Armteile
 Arm parts
 Pièces de bras PFAFF 1053
 Piezas del brazo PFAFF 1183

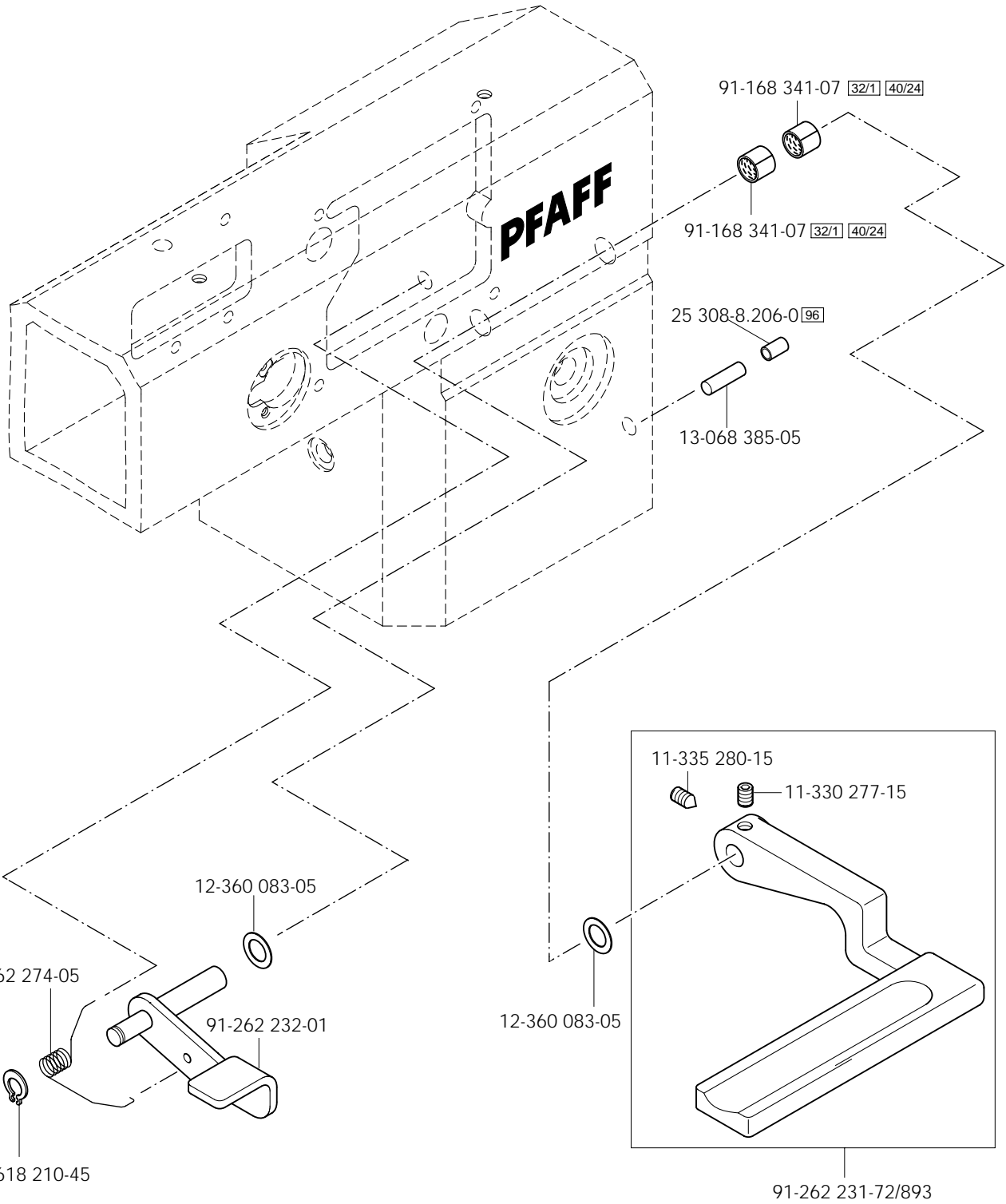
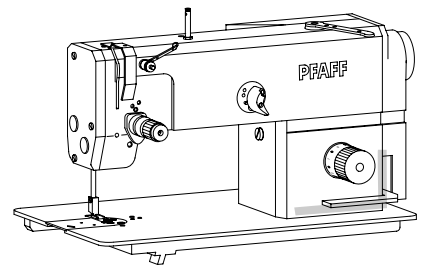

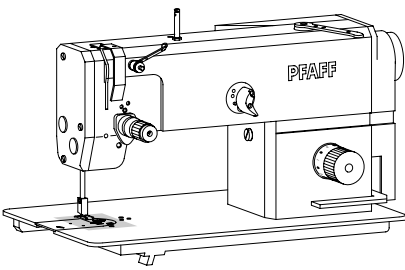

Grundplattenteile

Bedplate parts

Pièces du plateau fondamental

Piezas del cárter

PFAFF 1053

PFAFF 1183

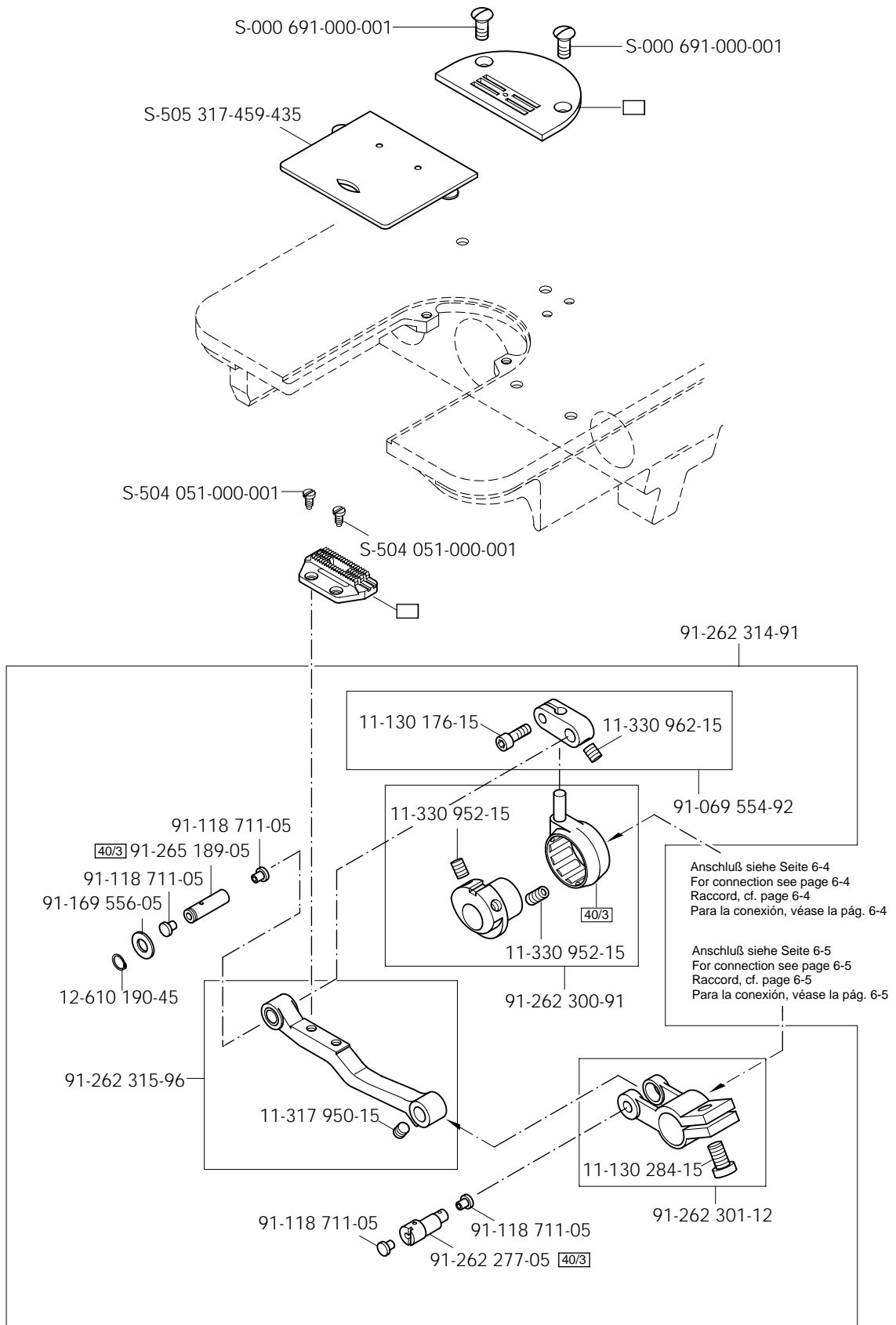

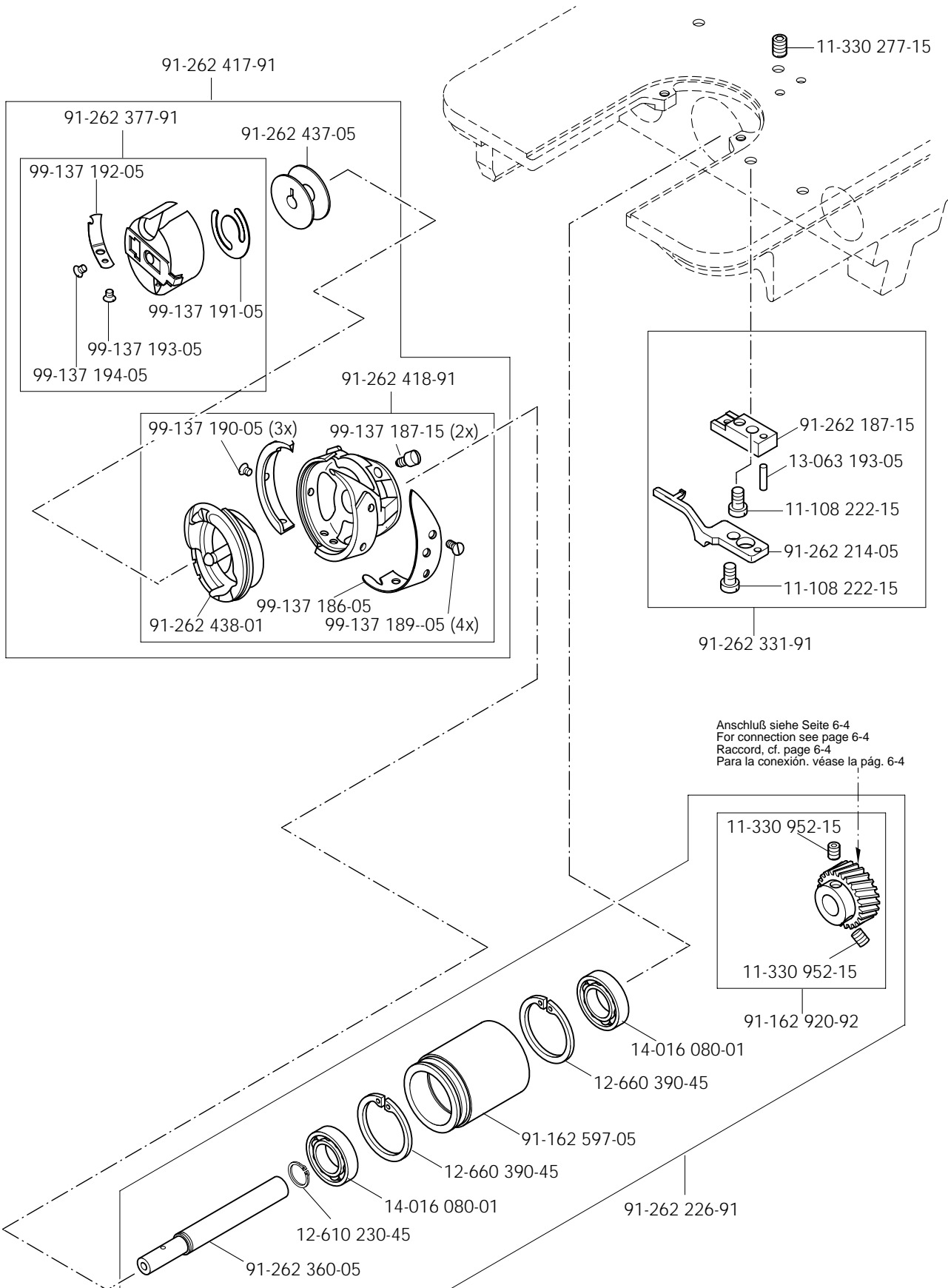
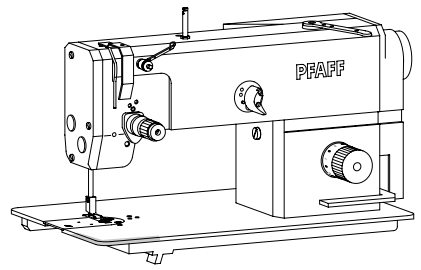

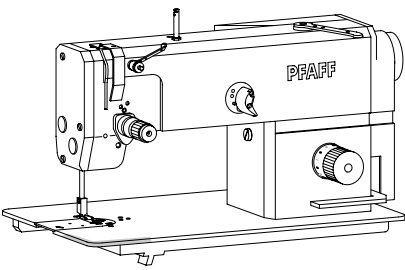

Grundplattenteile
 Bedplate parts
 Pièces du plateau fondamental
 Piezas del cárter

PFAFF 1183

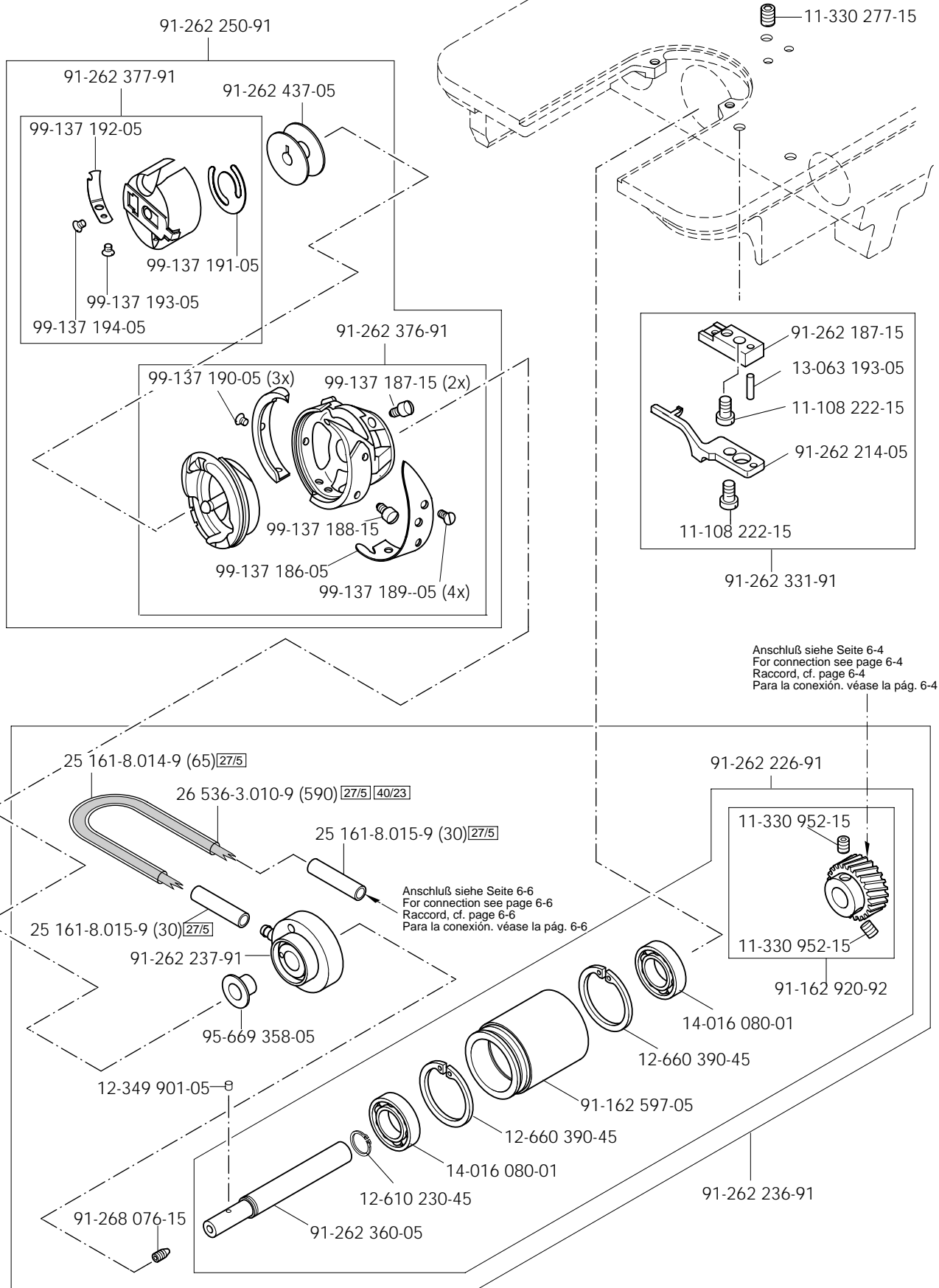

6

Grundplattenteile Bedplate parts Pièces du plateau fondamental Piezas del cárter

PFAFF 1053
PFAFF 1183

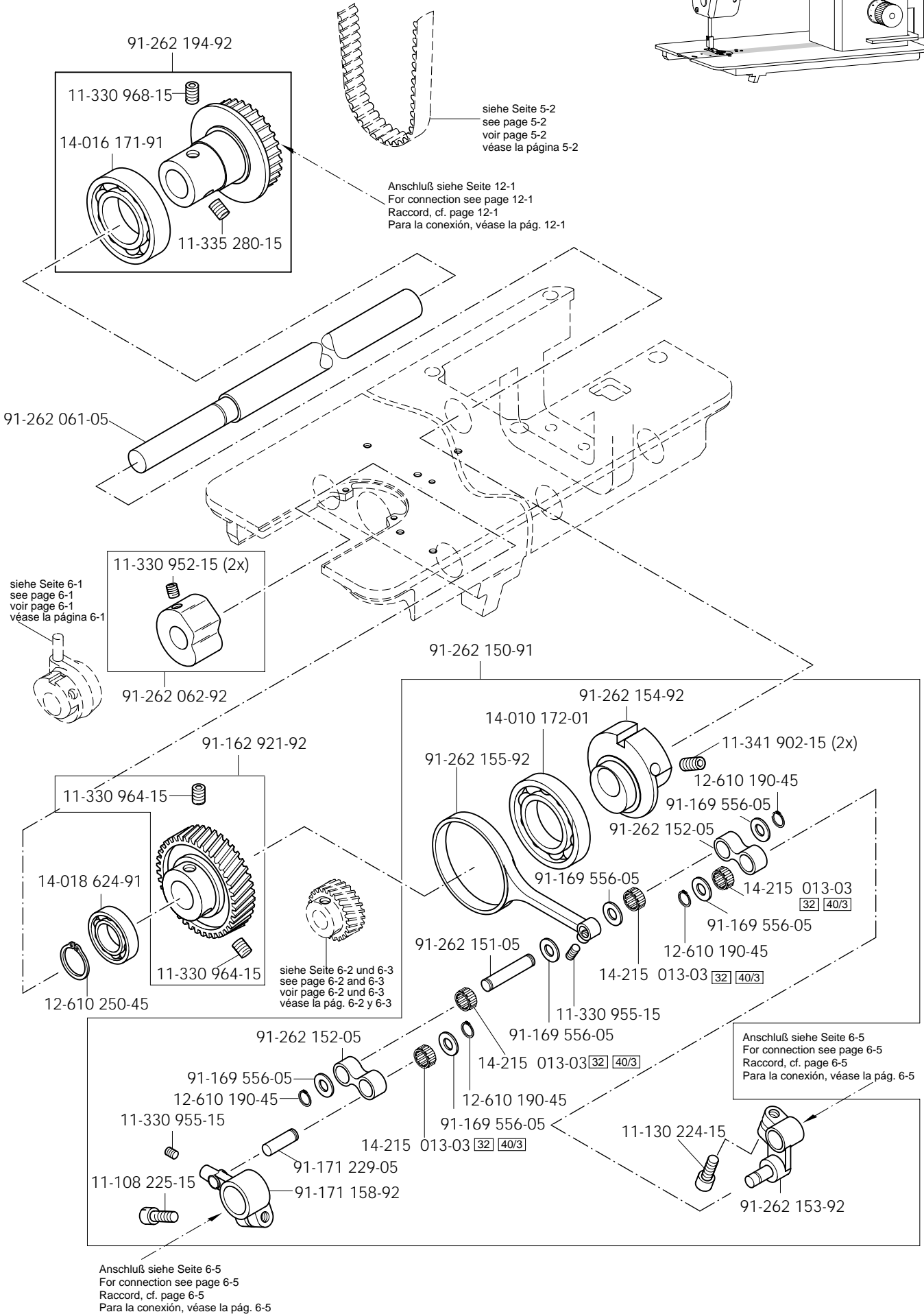
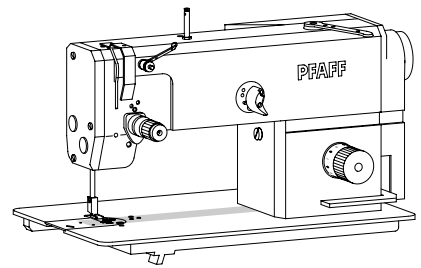

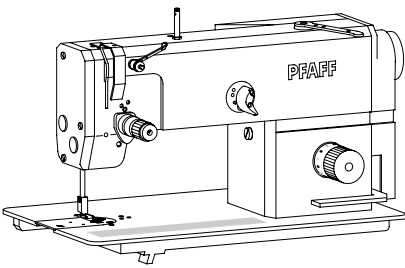

Grundplattenteile

Bedplate parts

Pièces du plateau fondamental

Piezas del cárter

PFAFF 1053

PFAFF 1183

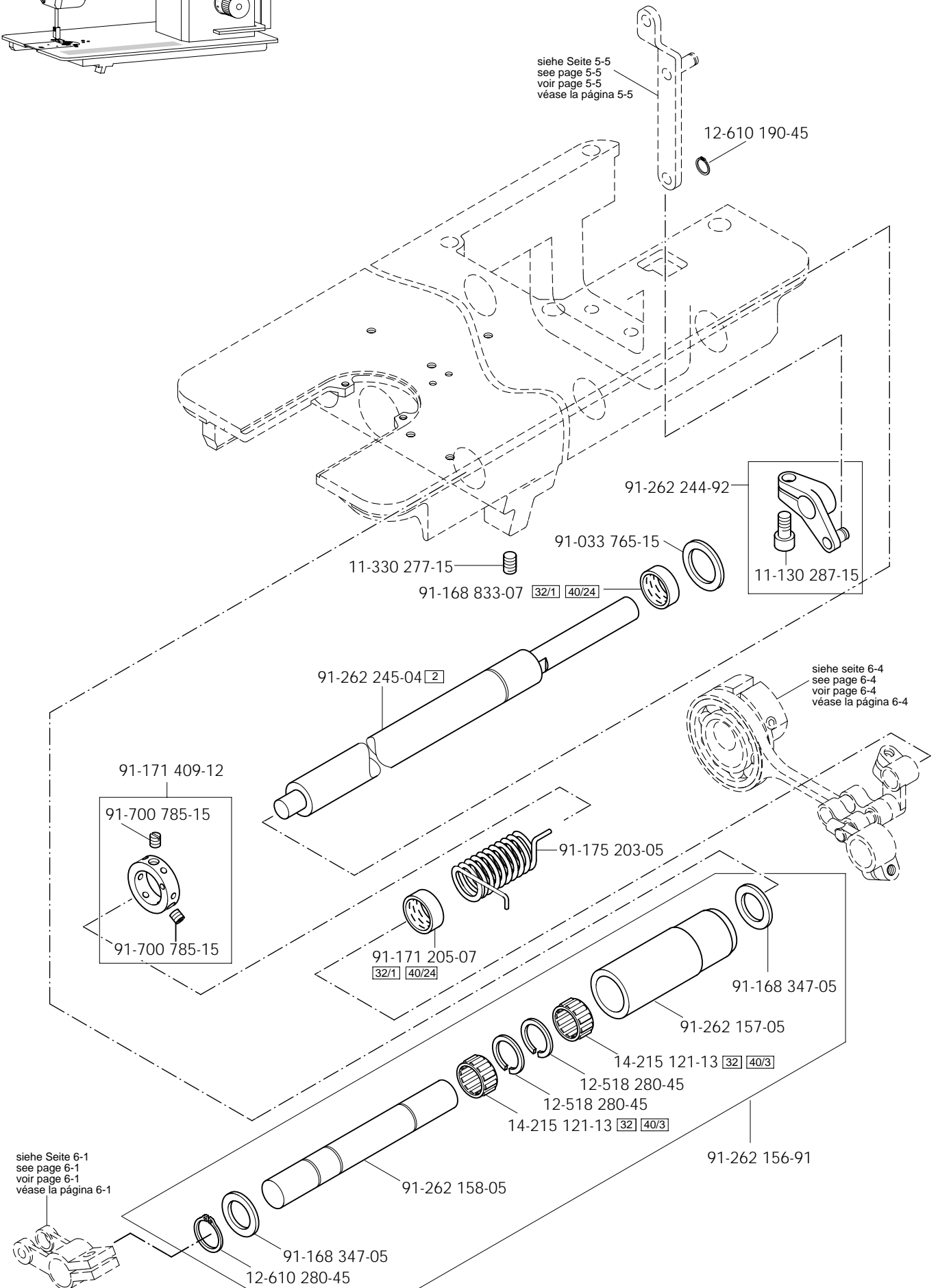

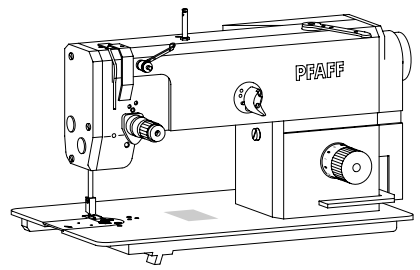

siehe Seite 4-3
 see page 4-3
 voir page 4-3
 véase la página 4-3

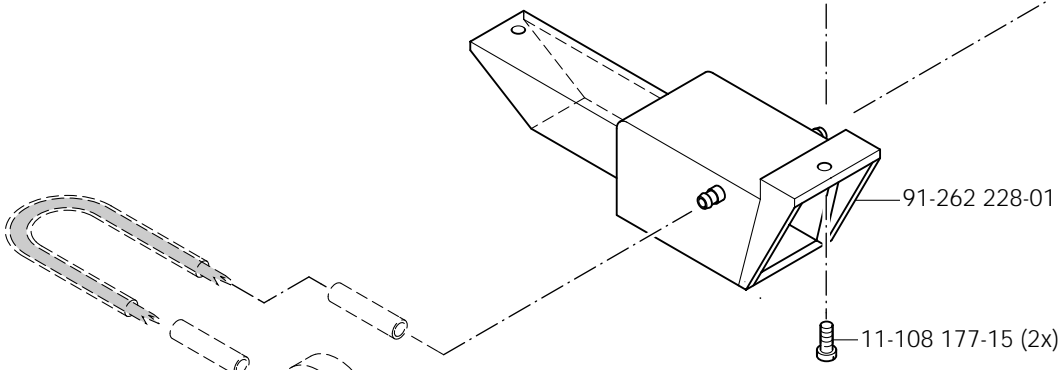
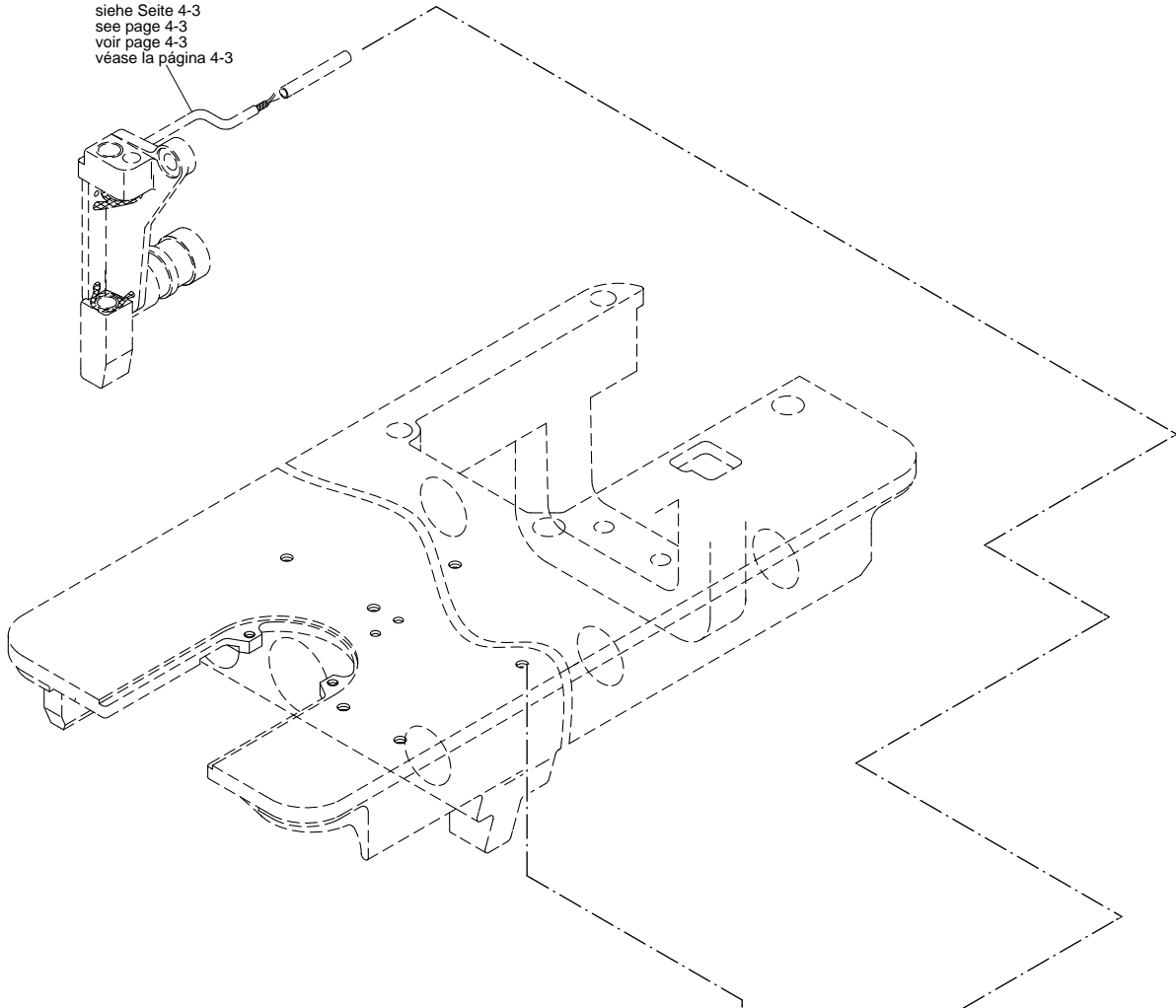

siehe Seite 6-3
 see page 6-3
 voir page 6-3
 véase la página 6-3

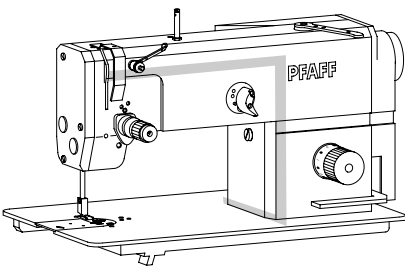

Grundplattenteile

Bedplate parts

Pièces du plateau fondamental

Piezas del cárter

PFAFF 1053

PFAFF 1183

siehe Seite 5-1
see page 5-1
voir page 5-1
véase la página 5-1

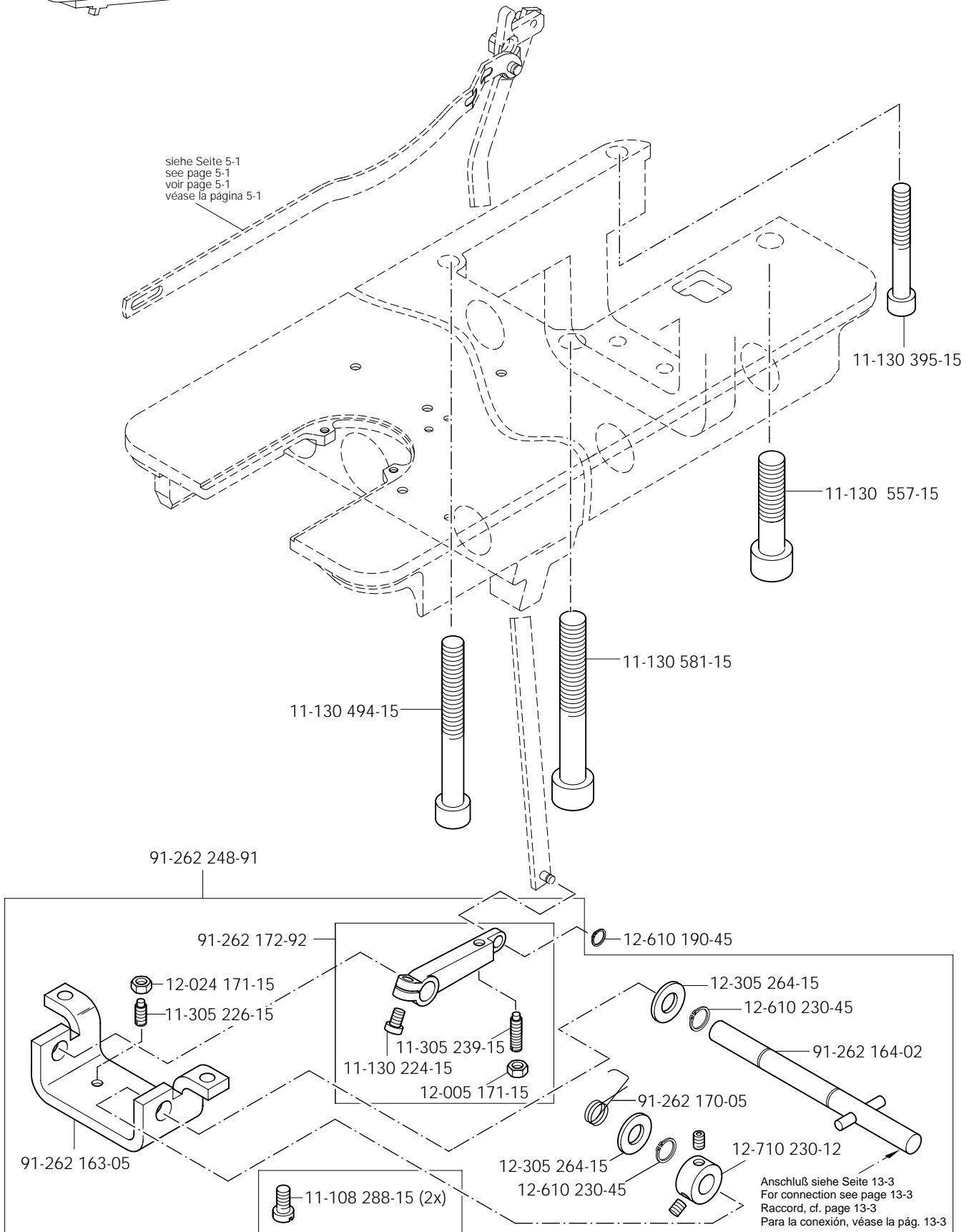

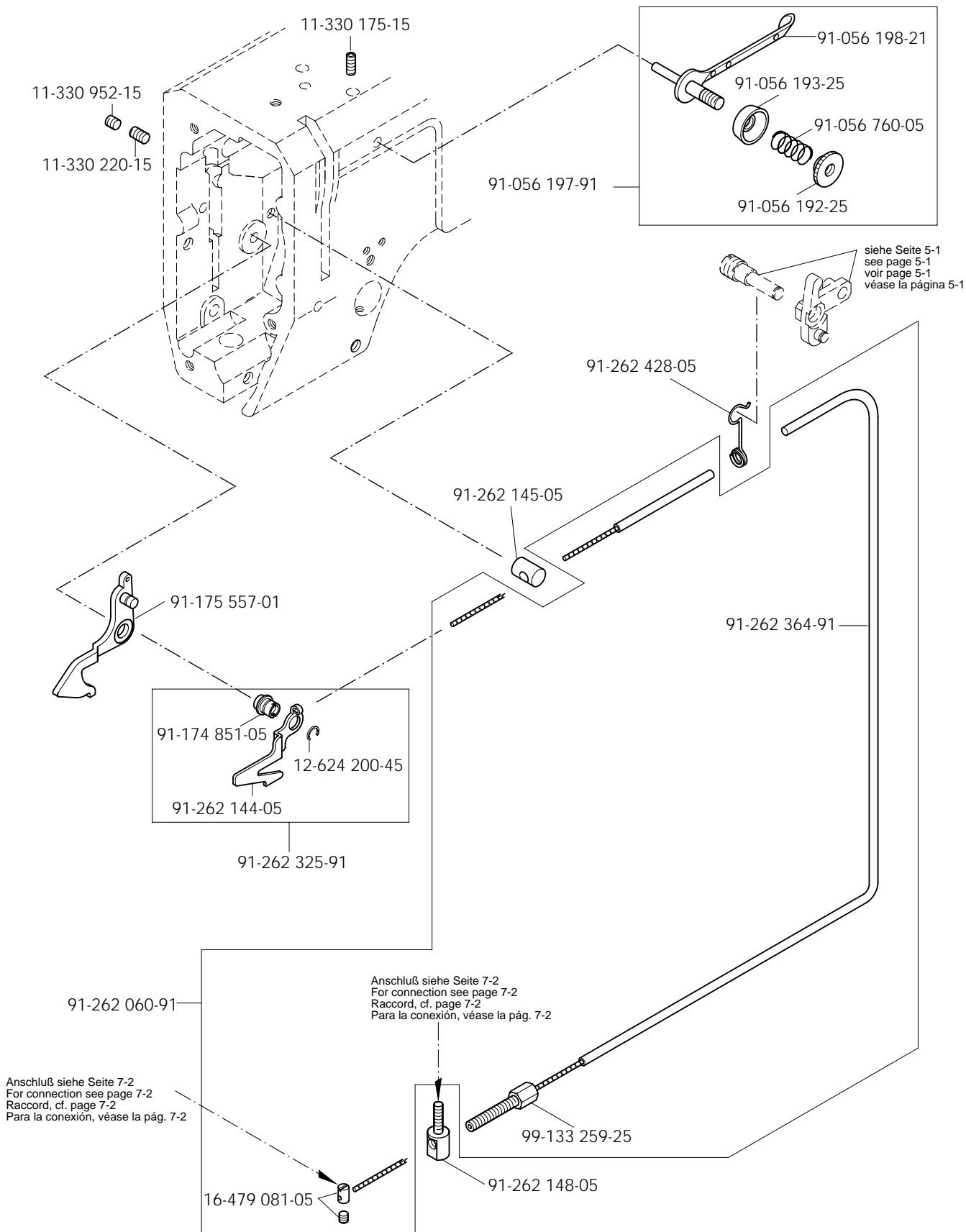
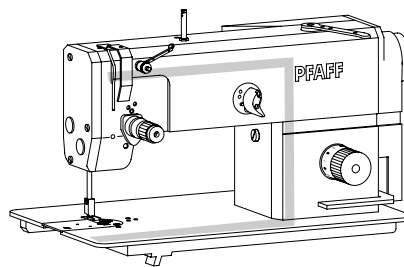

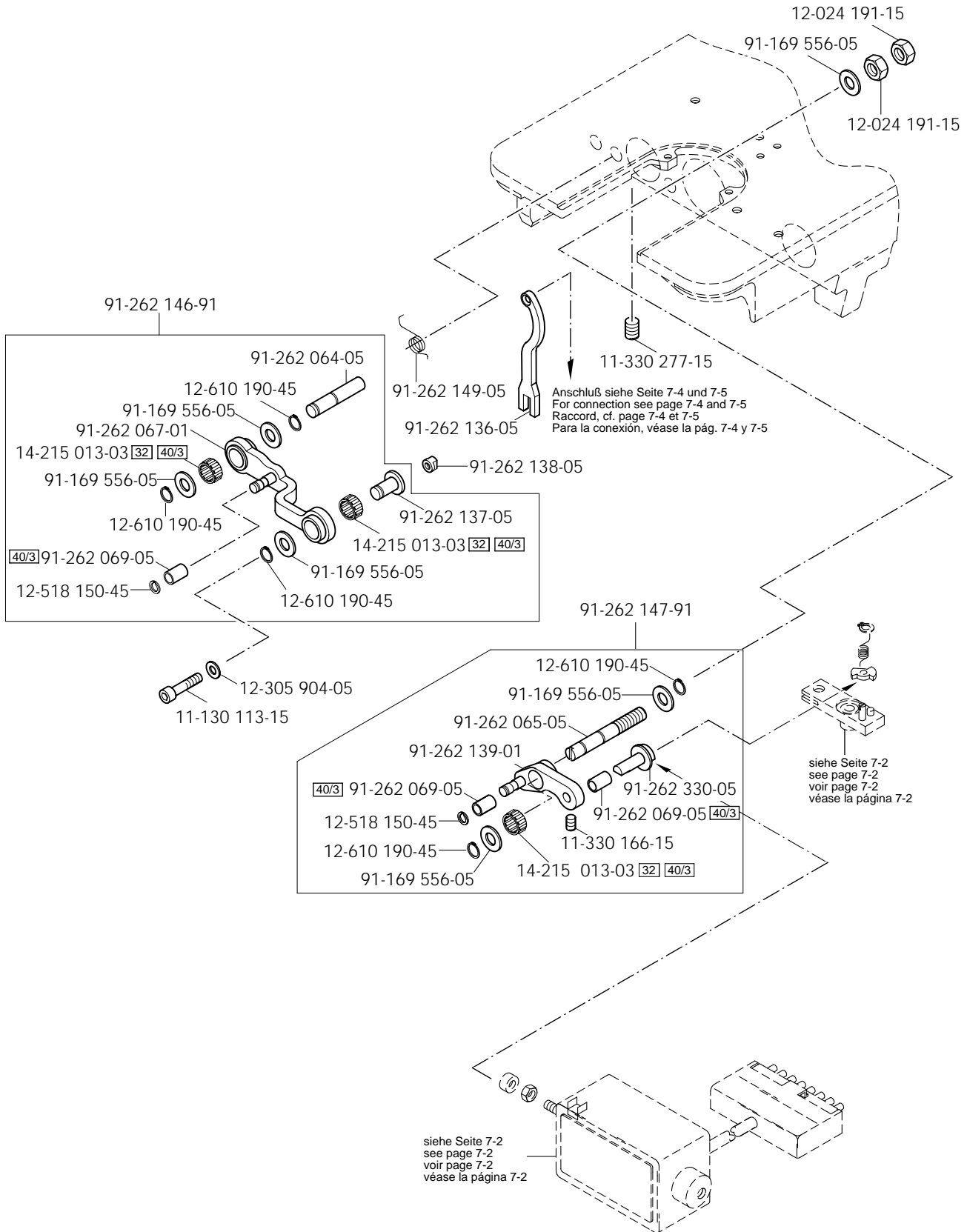
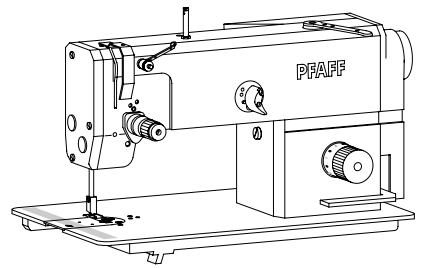

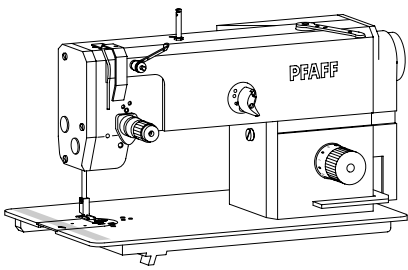

Fadenabschneid-Einrichtung (-900/22)
 Thread trimmer (-900/22)
 Coupe-fil (-900/22)
 Cortahilas (-900/22)

PFAFF 1053

7.01

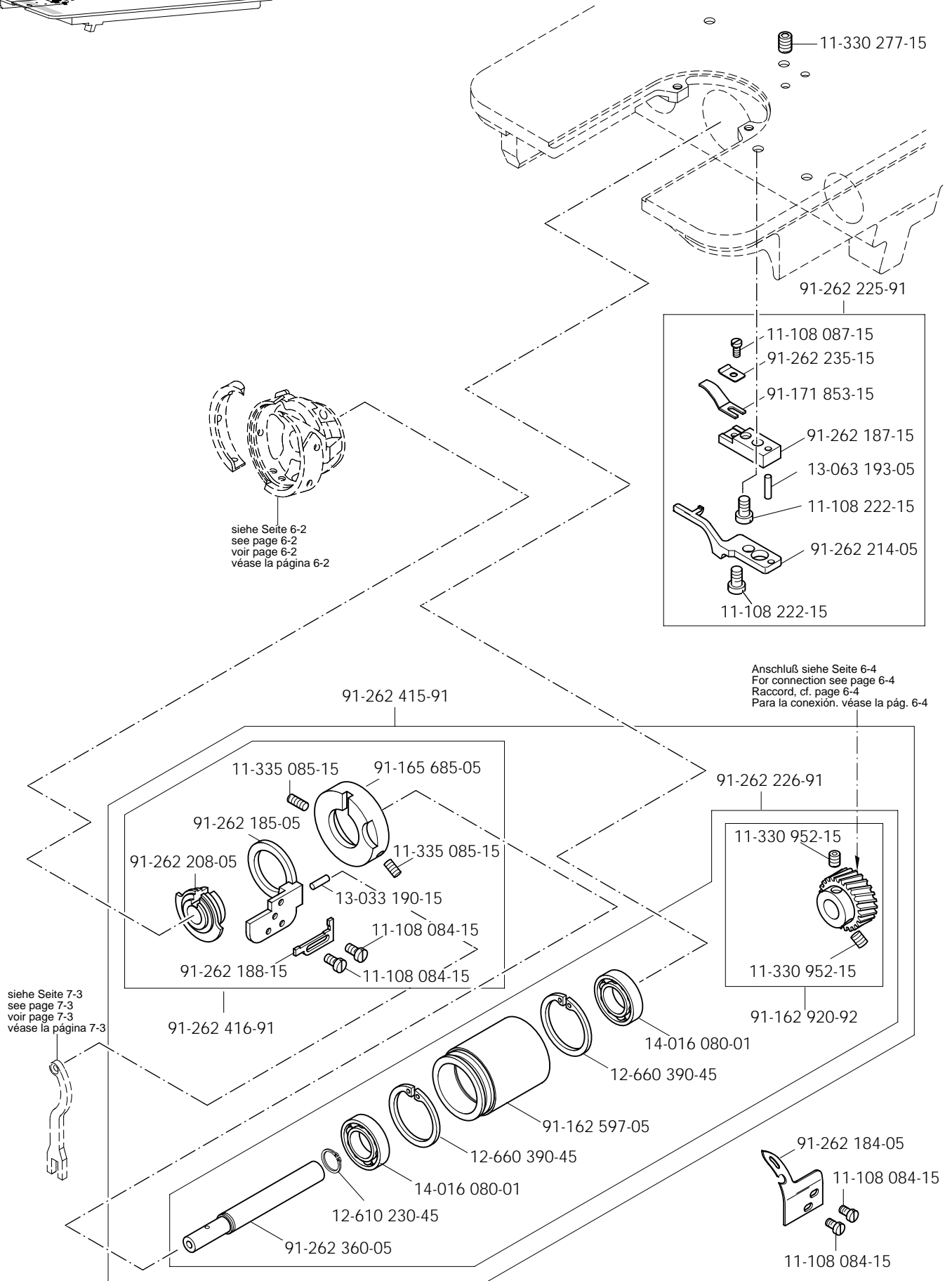

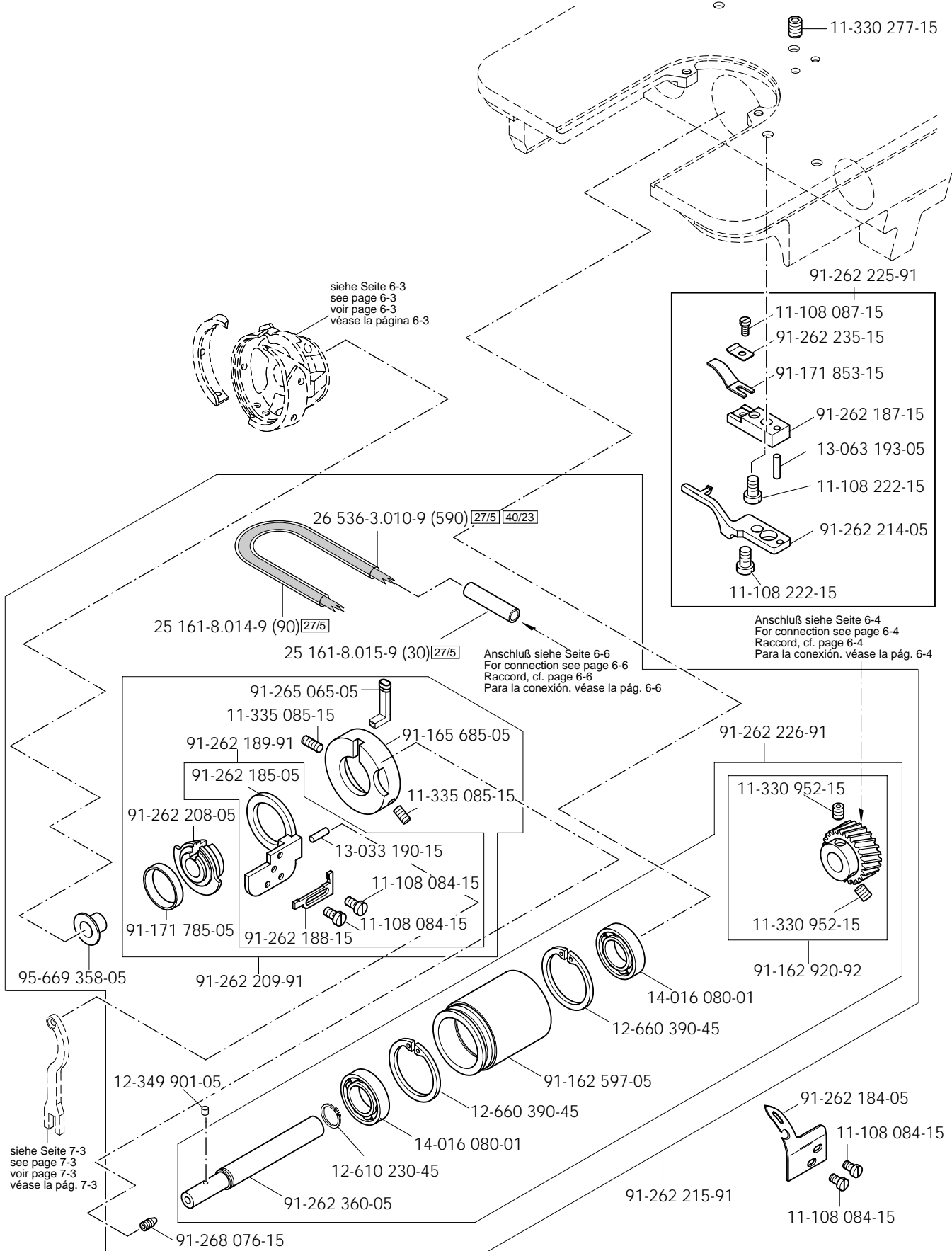
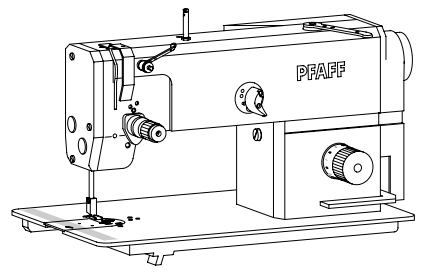

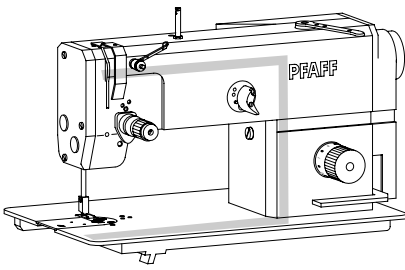

Fadenabschneid-Einrichtung (-900/24)
 Thread trimmer (-900/24)
 Coupe-fil (-900/24)
 Cortahilas (-900/24)

PFAFF 1053
 PFAFF 1183

7.02

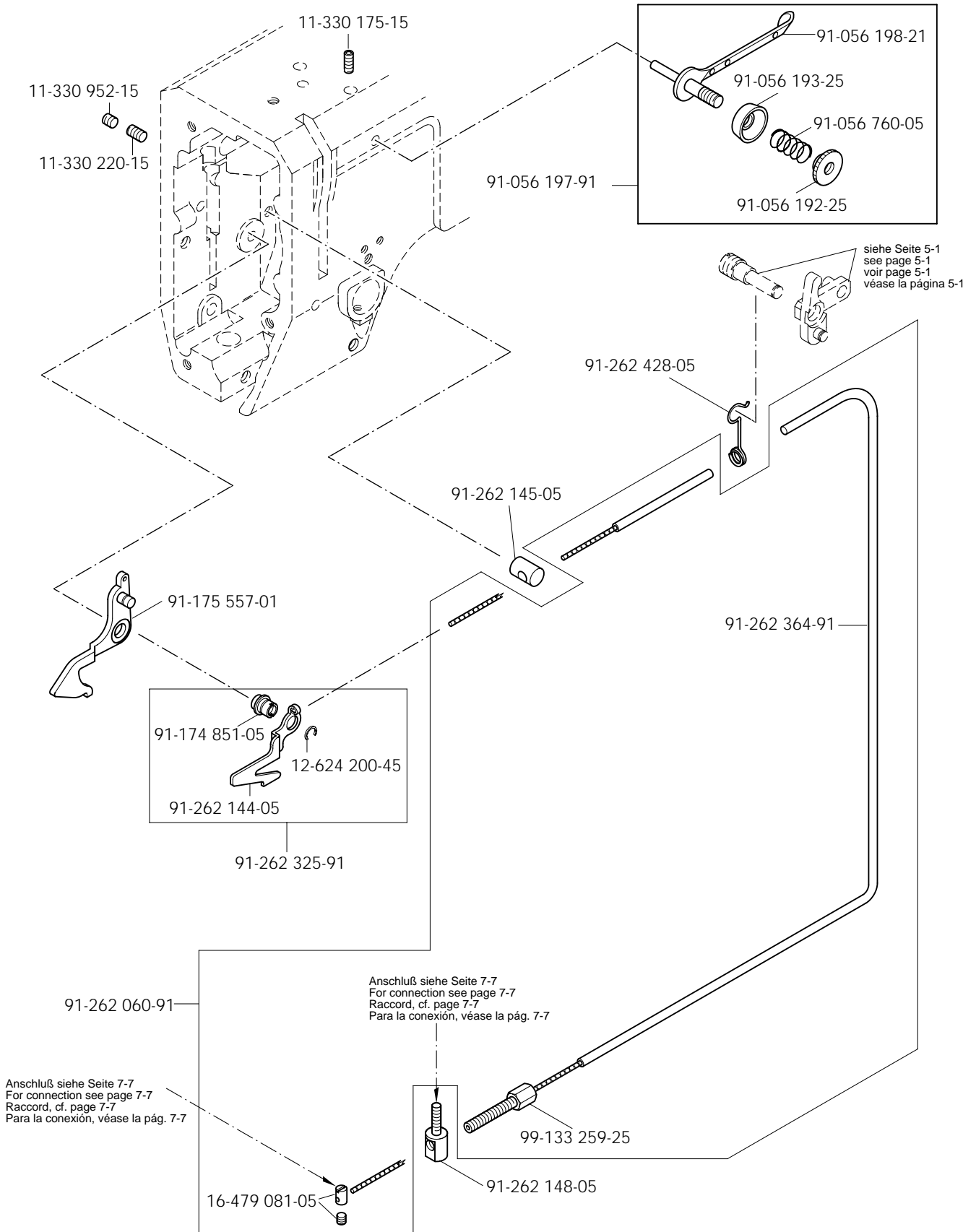

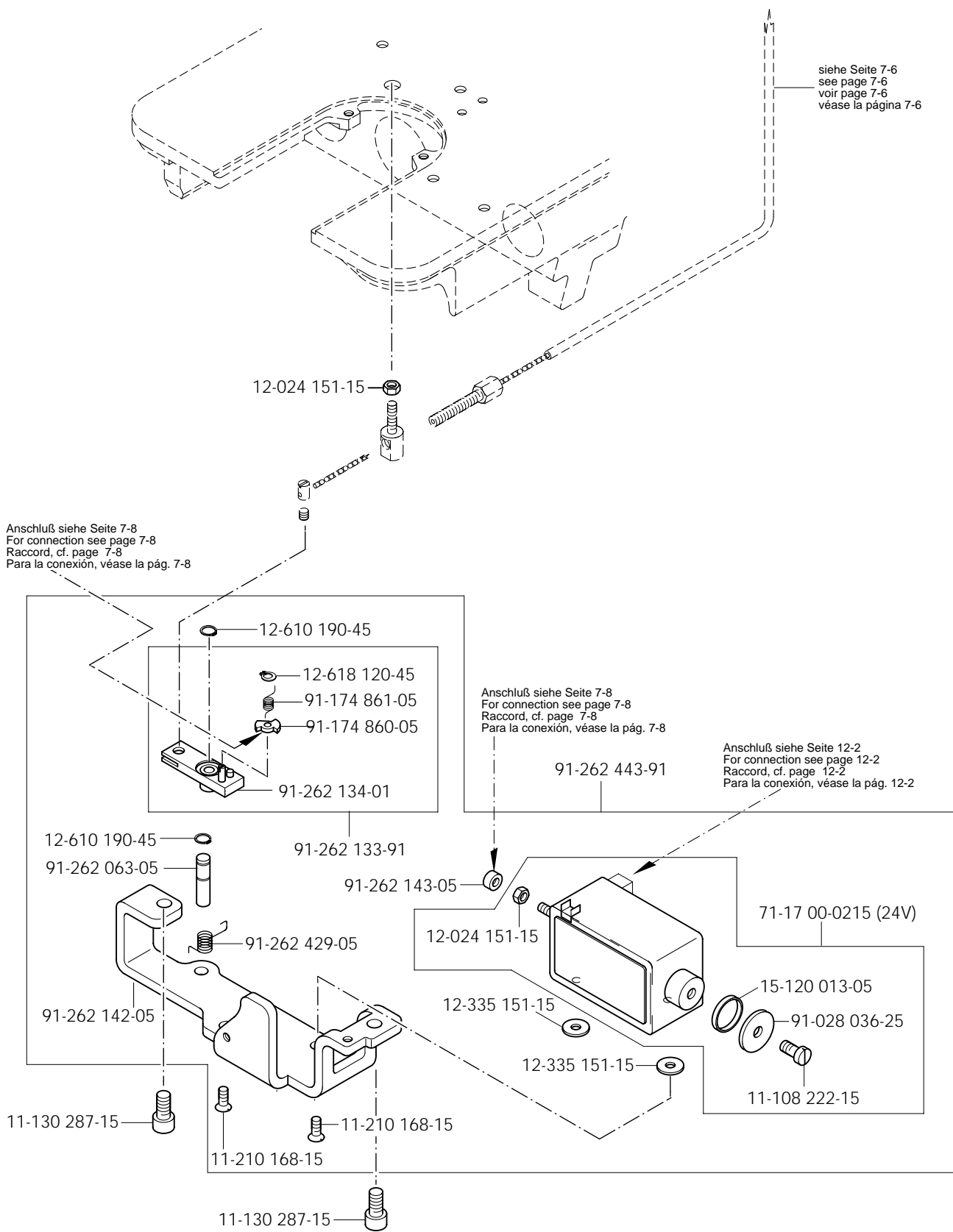
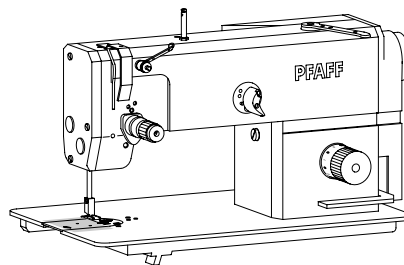

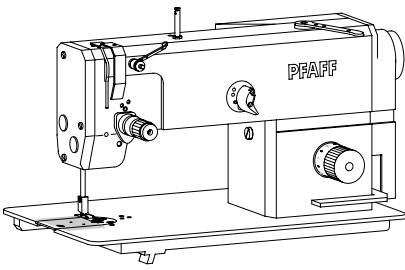

Fadenabschneid-Einrichtung (-900/24)
 Thread trimmer (-900/24)
 Coupe-fil (-900/24)
 Cortahilas (-900/24)

PFAFF 1053
 PFAFF 1183

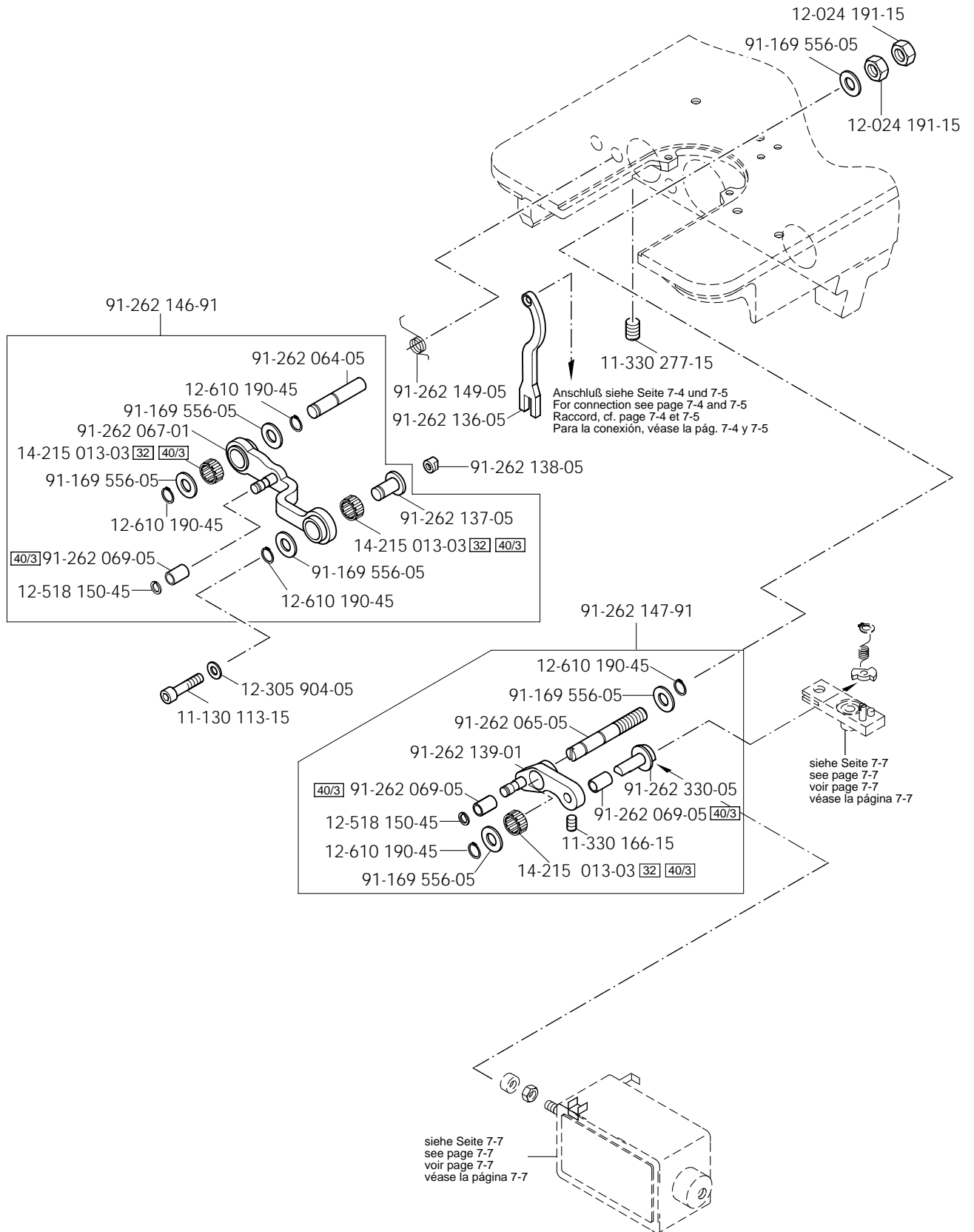

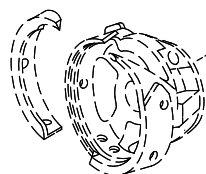
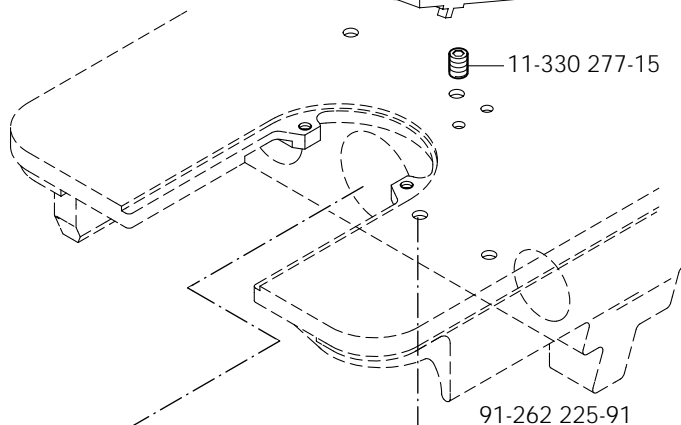
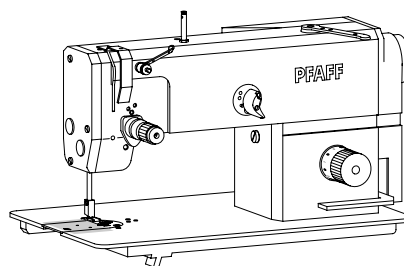

siehe Seite 6-2
 see page 6-2
 voir page 6-2
 véase la página 6-2

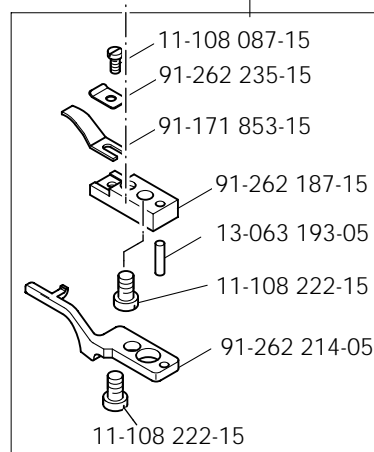

Anschluß siehe Seite 6-4
 For connection see page 6-4
 Raccord, cf. page 6-4
 Para la conexión, véase la pág. 6-4

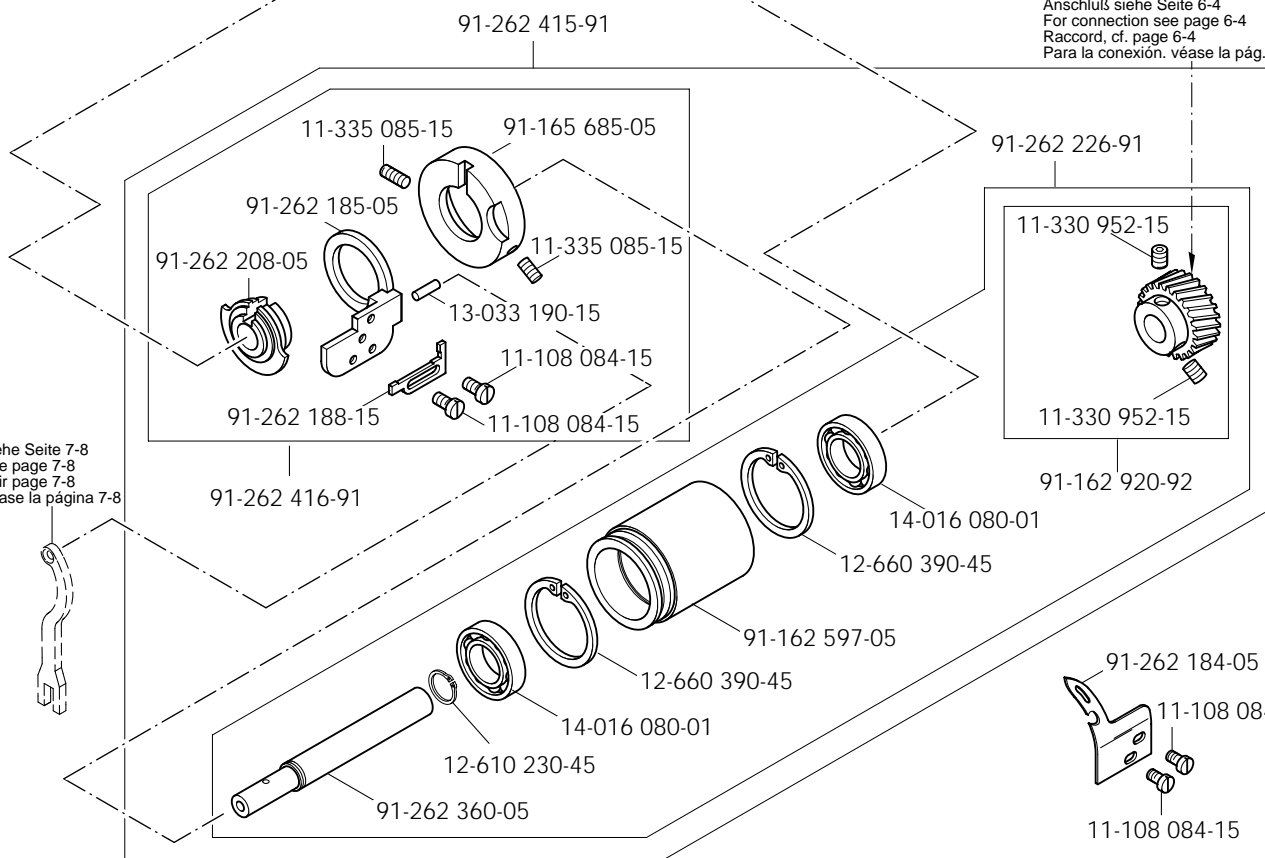

siehe Seite 7-8
 see page 7-8
 voir page 7-8
 véase la página 7-8

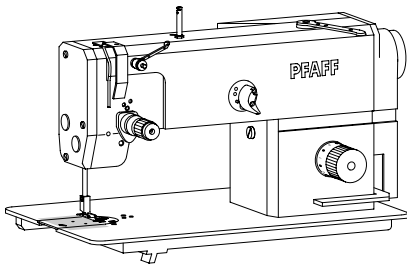

Fadenabschneid-Einrichtung (-900/24)
 Thread trimmer (-900/24)
 Coupe-fil (-900/24)
 Cortahilas (-900/24)

PFAFF 1183

7.02

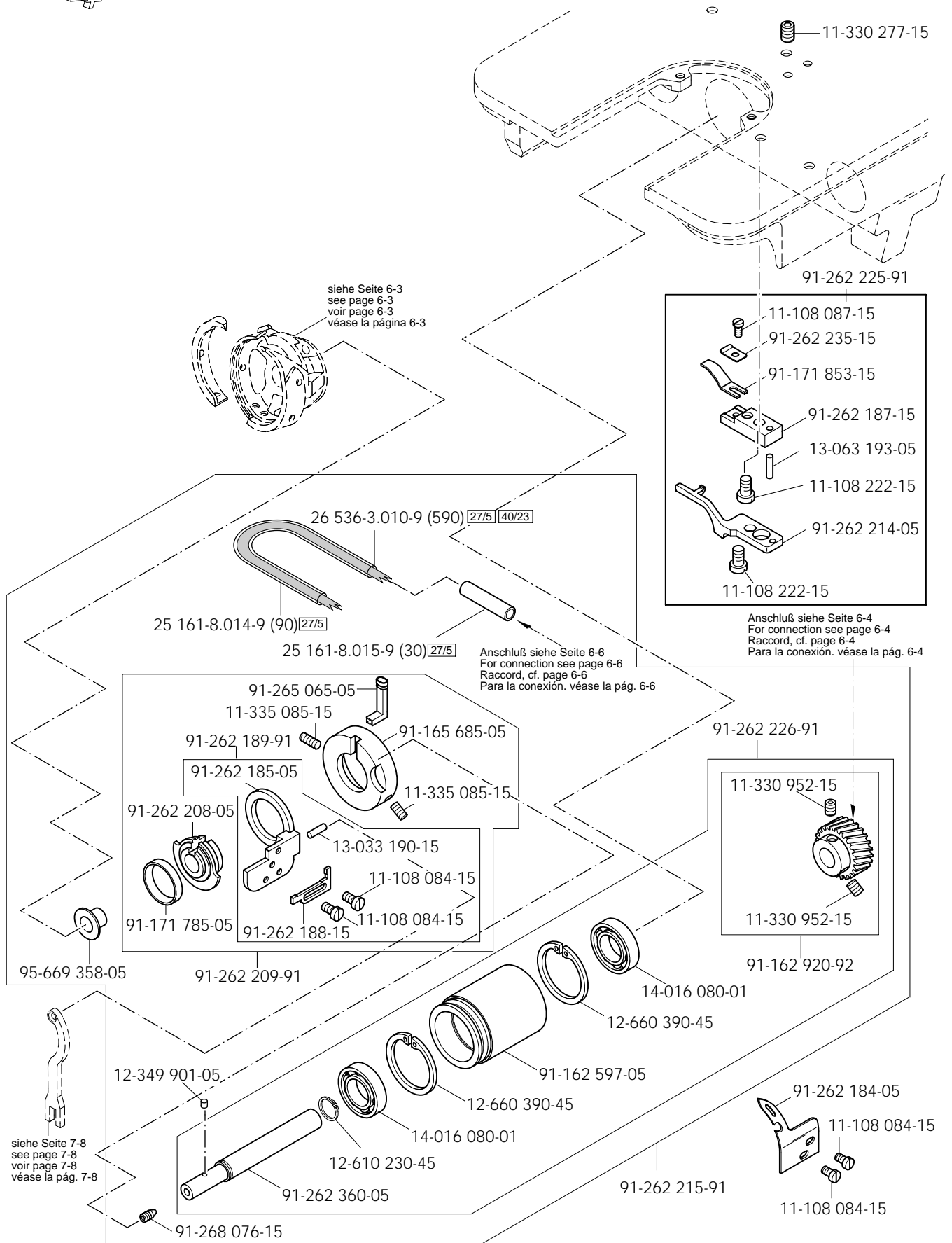

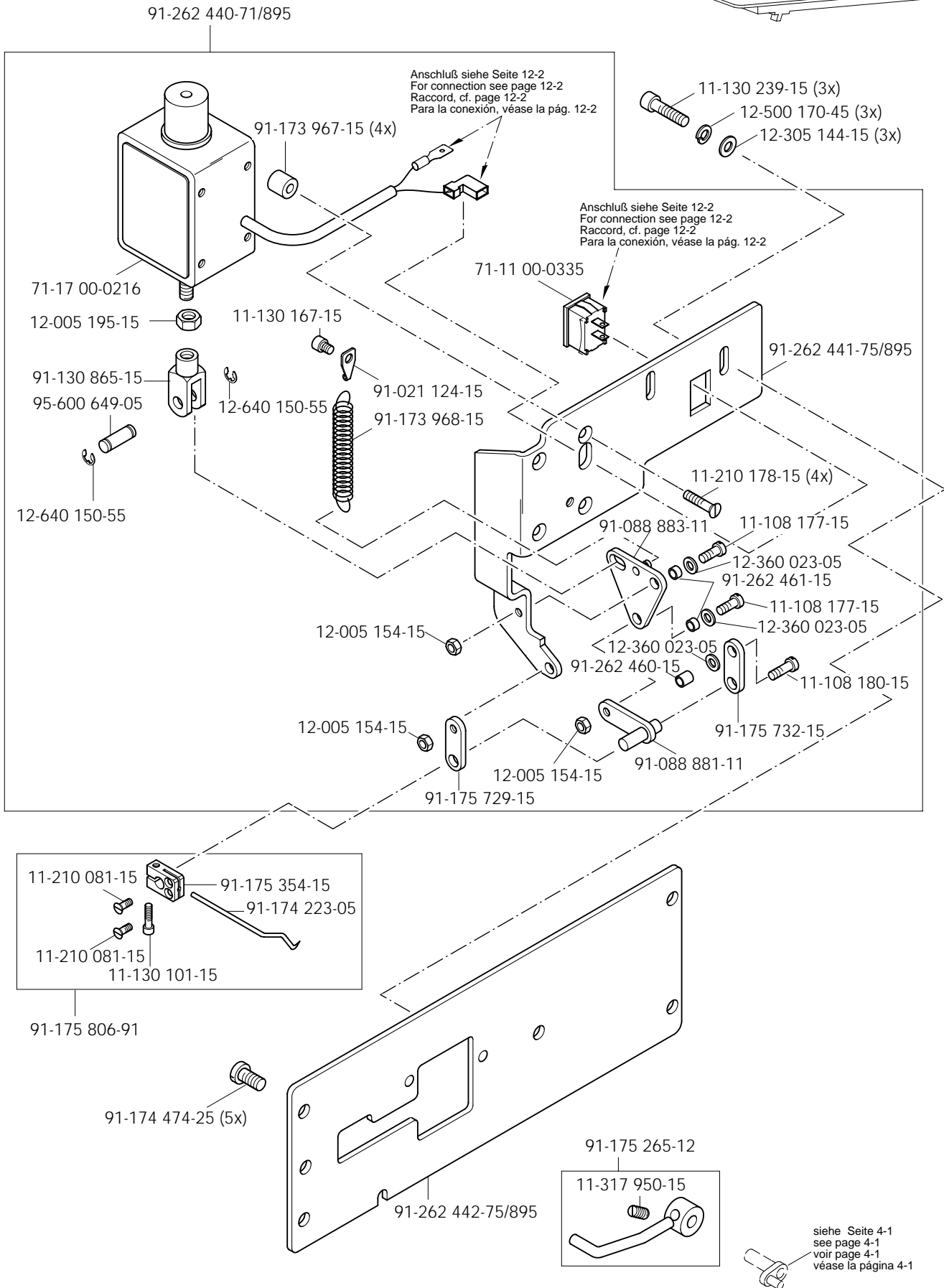
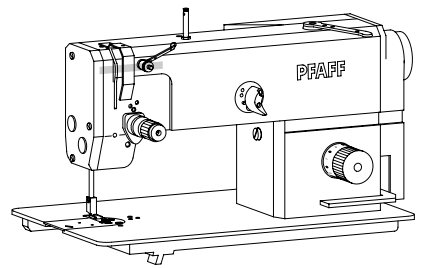

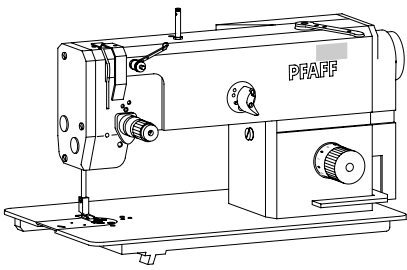

Presserfuß-Automatik (-910/06)
 Automatic presser lifter (-910/06)
 Releve-pied automatique (-910/06)
 Alzaprensatelas (-910/06)

PFAFF 1053-900/24
 PFAFF 1183-900/24

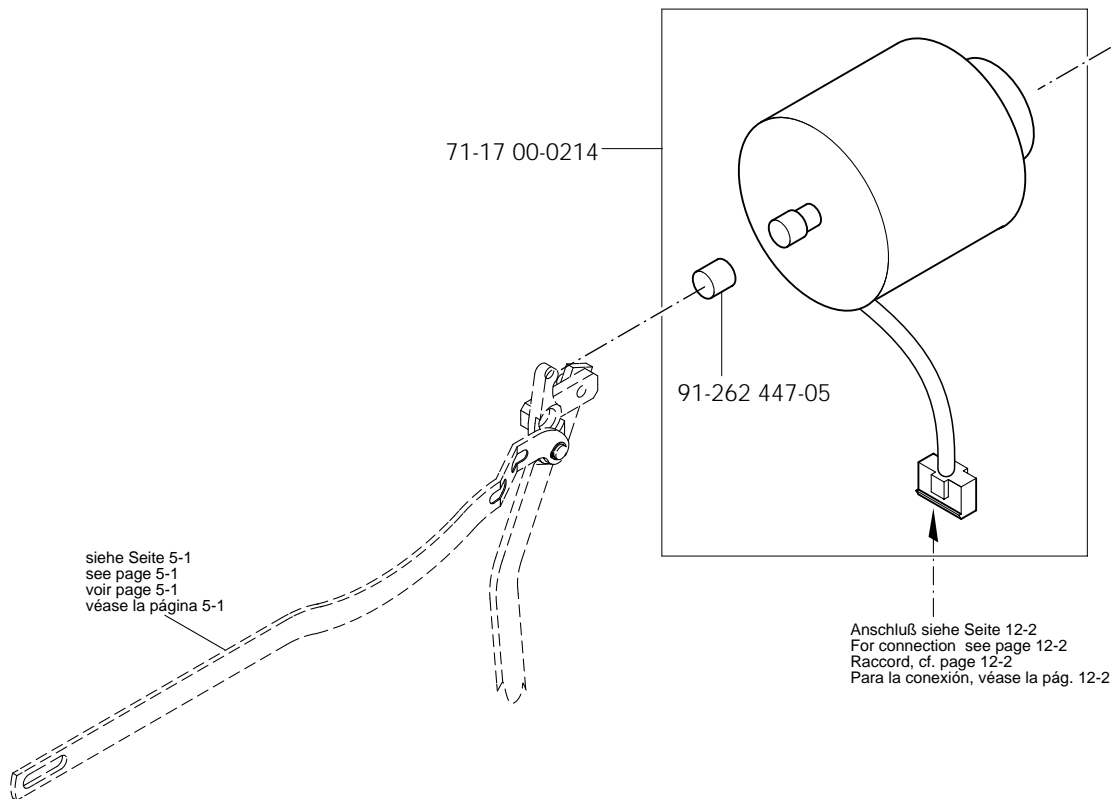
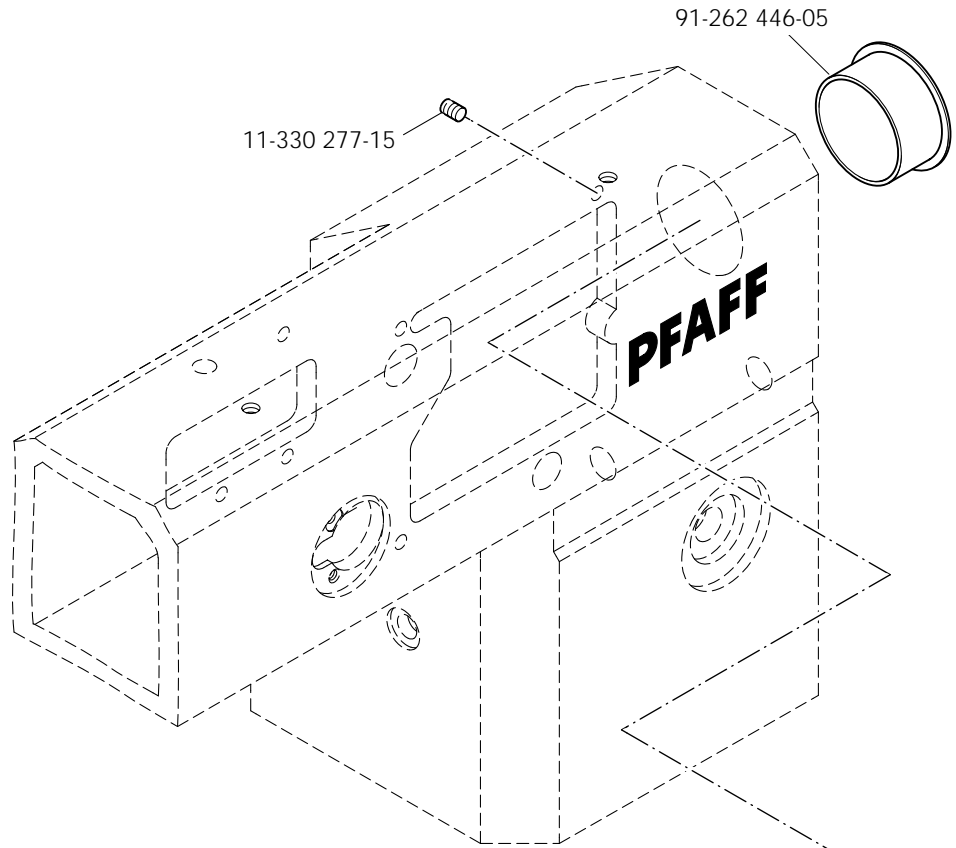

siehe Seite 5-1
 see page 5-1
 voir page 5-1
 véase la página 5-1

Anschluß siehe Seite 12-2
 For connection see page 12-2
 Raccord, cf. page 12-2
 Para la conexión, véase la pág. 12-2

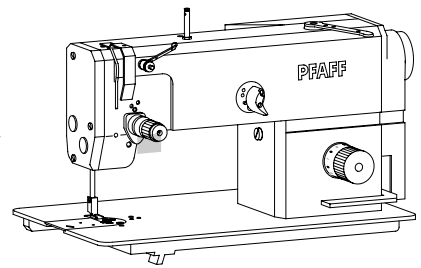

Anschluß siehe Seite 12-2
 For connection see page 12-2
 Raccord, cf. page 12-2
 Para la conexión, véase la pág. 12-2

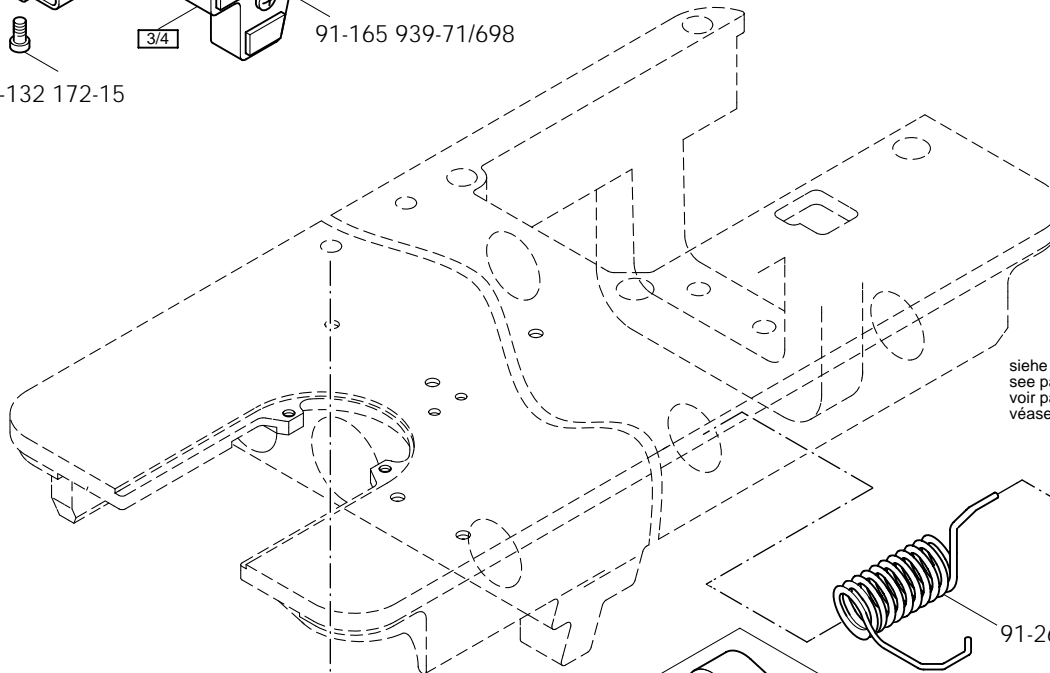
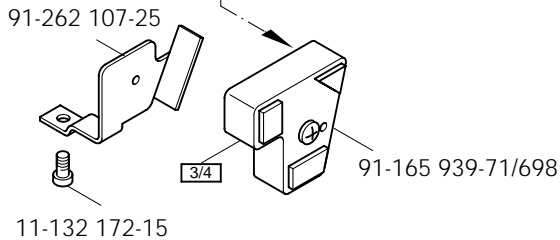

siehe Seite 6-5
 see page 6-5
 voir page 6-5
 véase la página 6-5

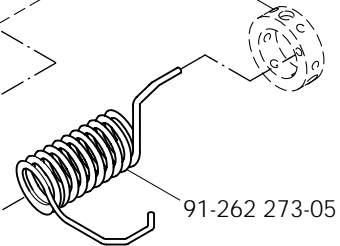

91-262 273-05
 91-262 372-92

91-262 369-91

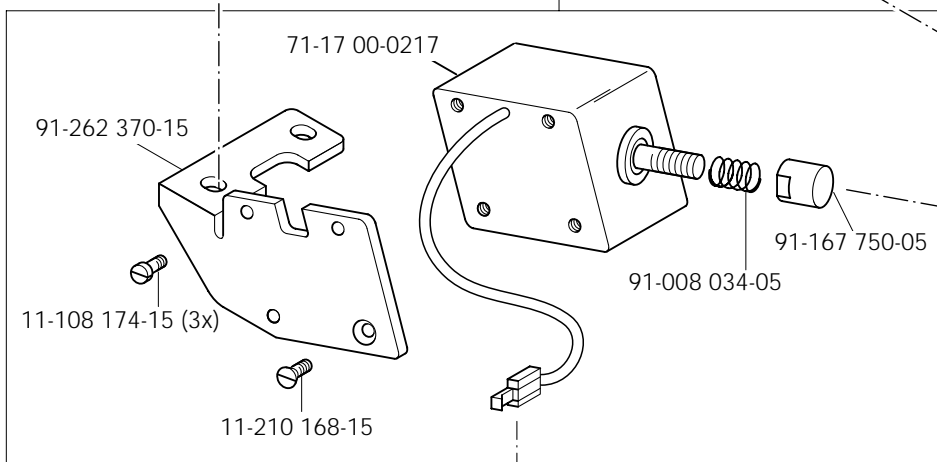

Anschluß siehe Seite 12-2
 For connection see page 12-2
 Raccord, cf. page 12-2
 Para la conexión, véase la pág. 12-2

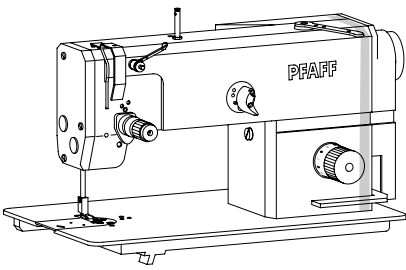

Anbausatz für externen Motor
 Mounting kit for external motor
 Jeu de pièces pour moteur externe
 Juego de piezas acoplables para motor externo

PFAFF 1053
 PFAFF 1183

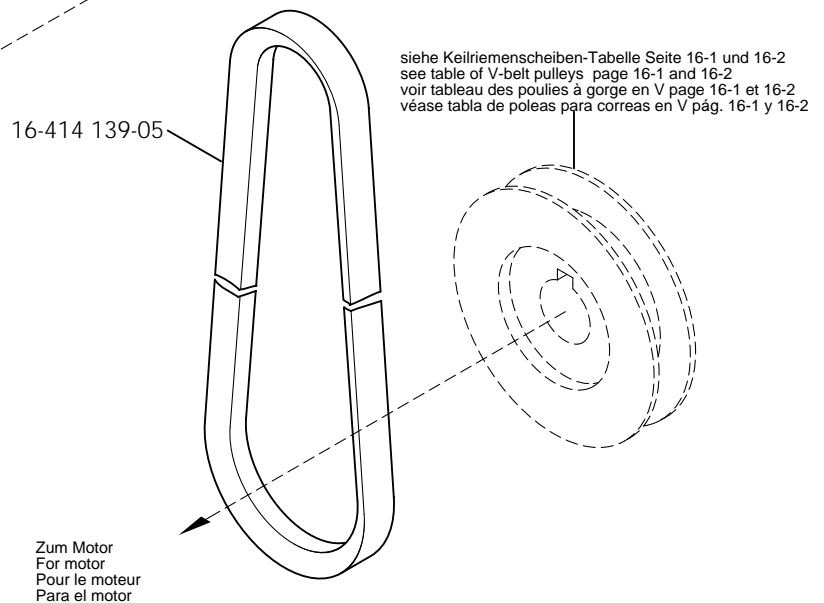
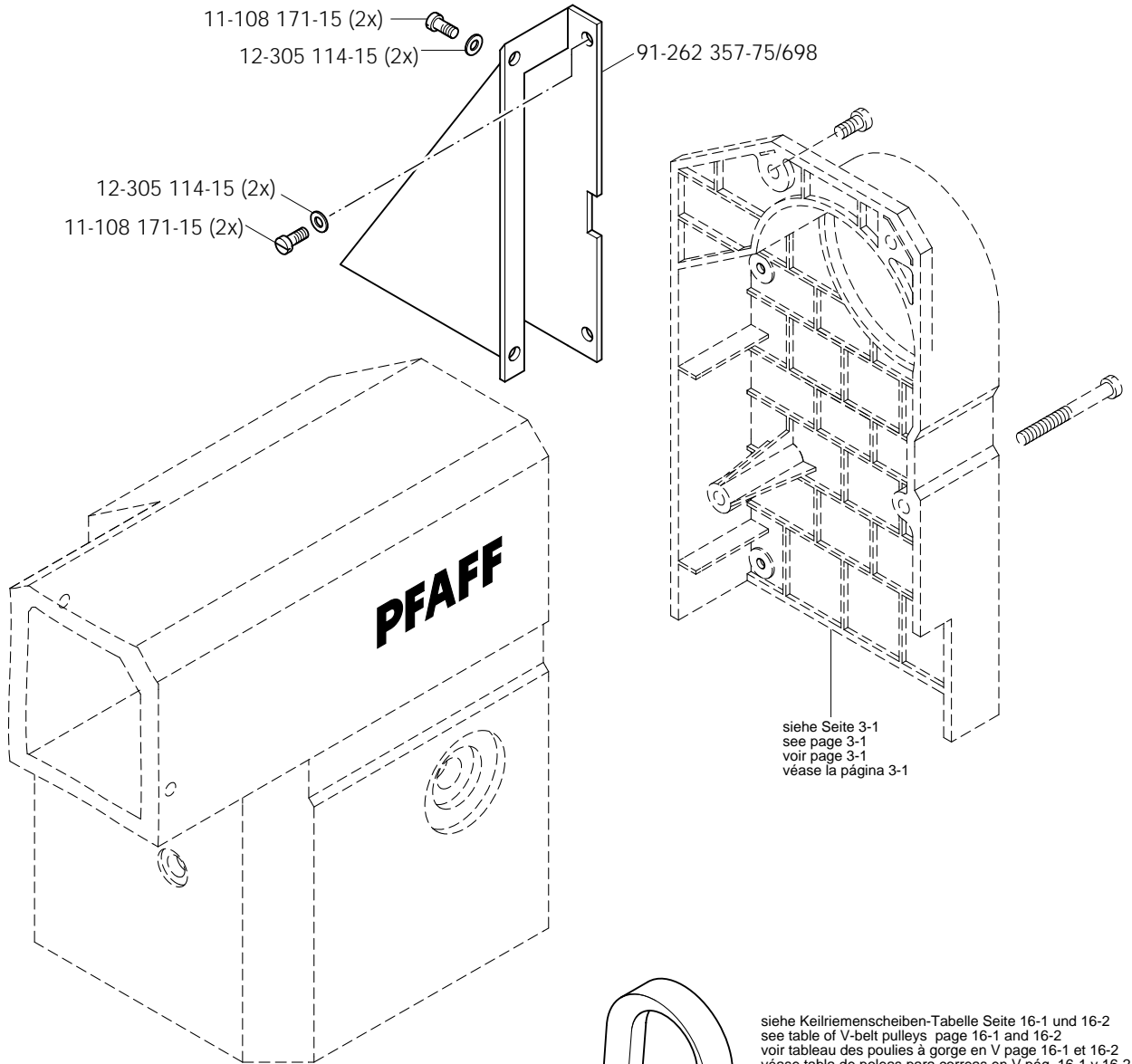

12.01

Einbaumotor
Built-in motor
Moteur incorporé
Motor incorporado

PFAFF 1053
PFAFF 1183

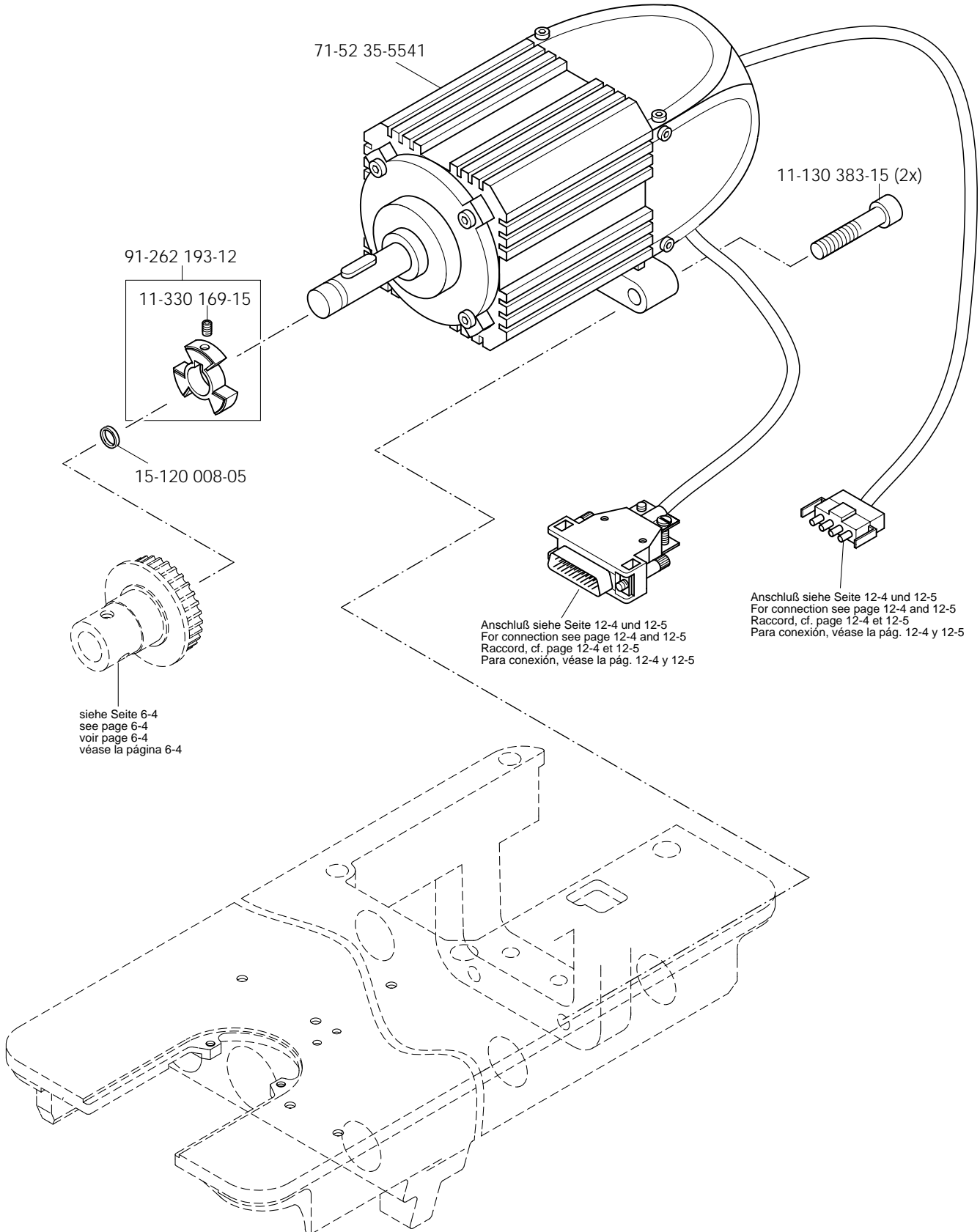
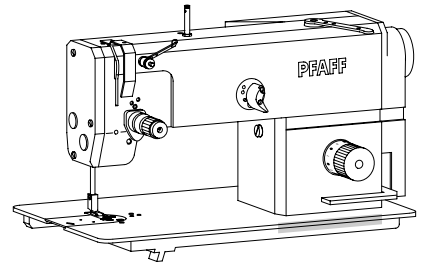

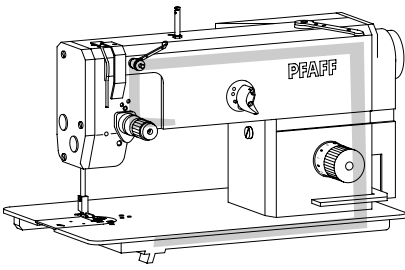

Kabelbaum zum Oberteil
Cable tree to sewing head

Faisceau de câbles vers la tête de machine
Mazo de cables para el cabezal

PFAFF 1053-900/24
PFAFF 1183-900/24

12.02

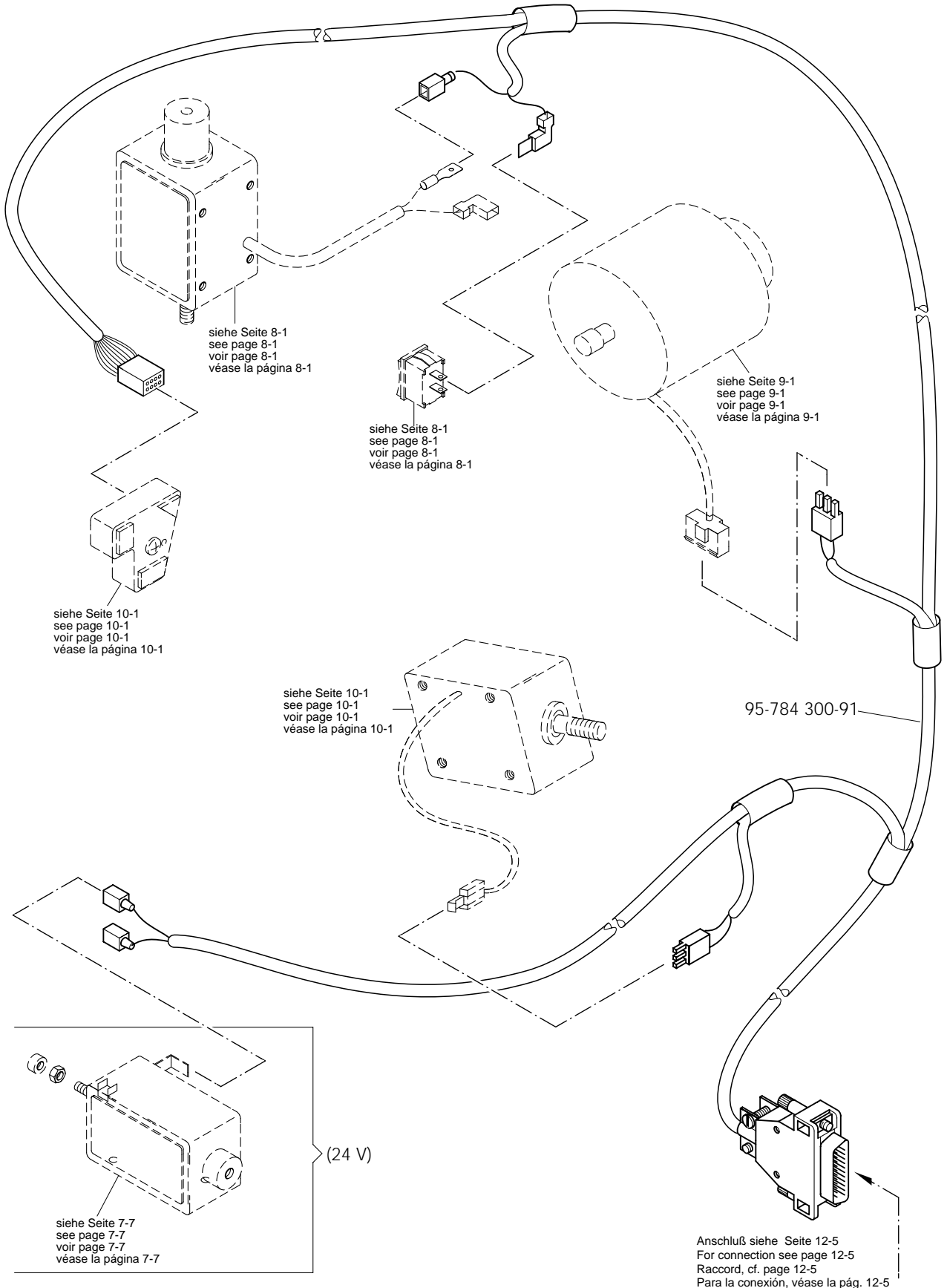

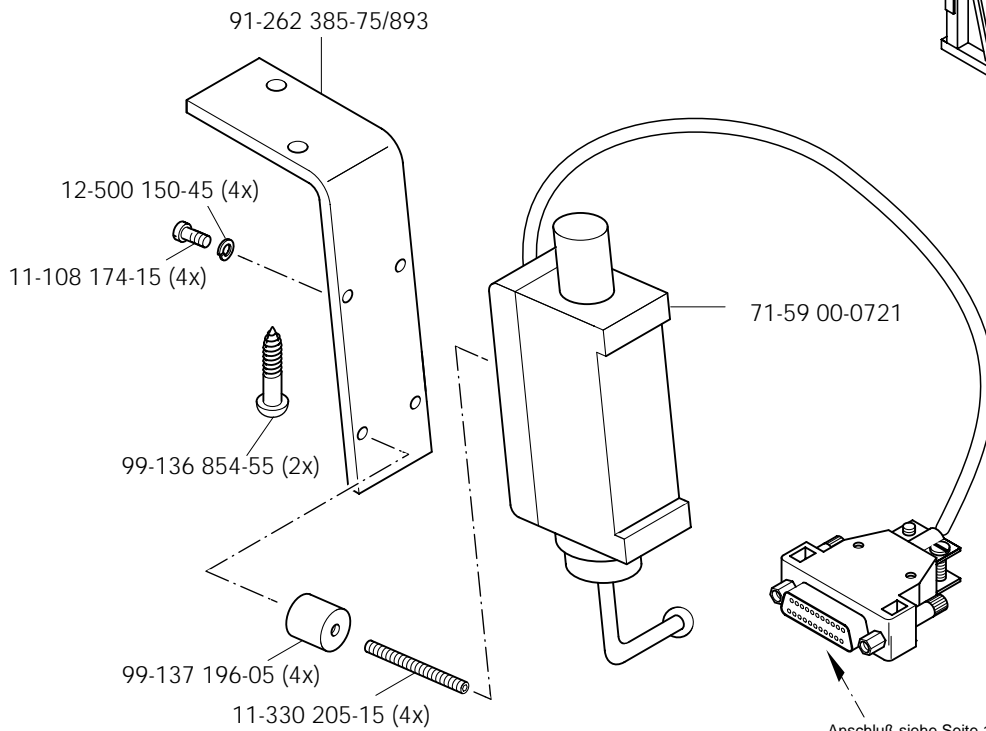
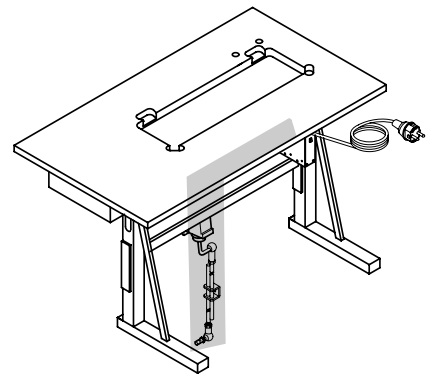

Anschluß siehe Seite 12-4 und 12-5
For connection see page 12-4 and 12-5
Raccoard, cf. page 12-4 et 12-5
Para la conexión, véase la pág. 12-4 y 12-5

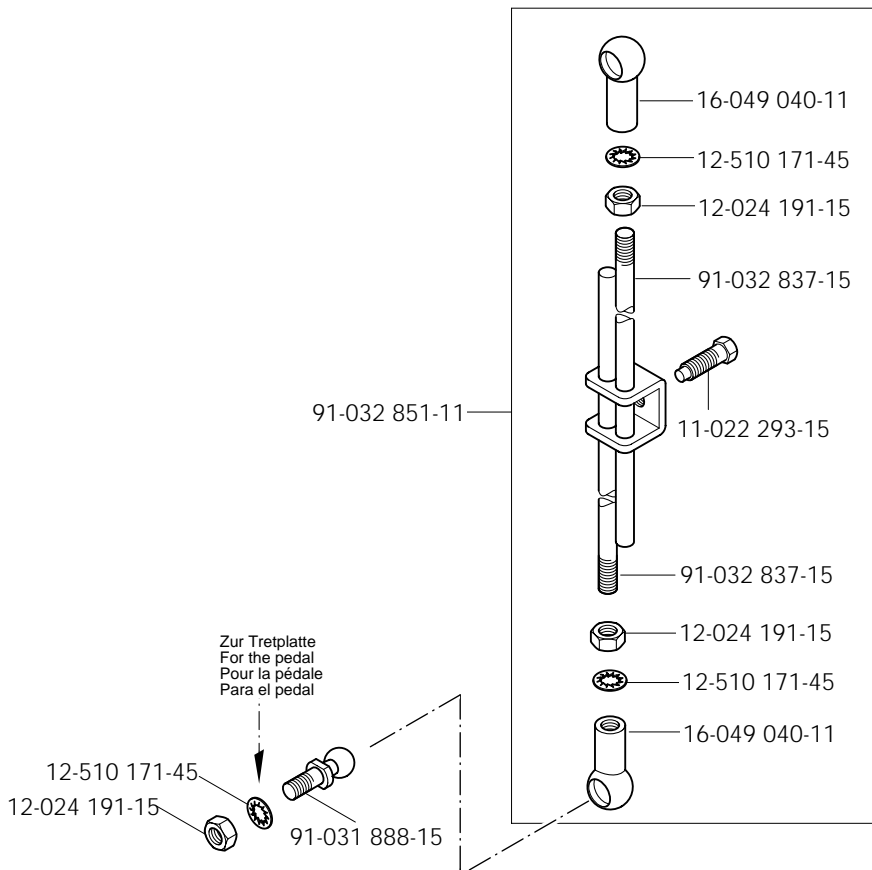

Steuerkasten

Control box

Boîtier de contrôle

Caja de mandos

PFAFF 1053-900/22

PFAFF 1183-900/22

12.04

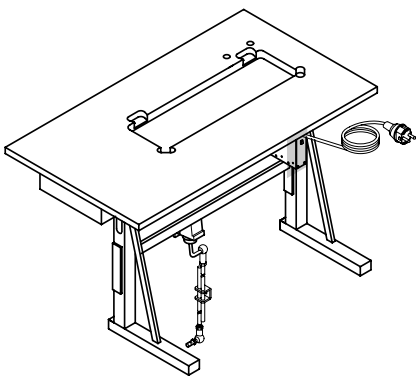

siehe Seite 12-1
see page 12-1
voir page 12-1
véase la página 12-1

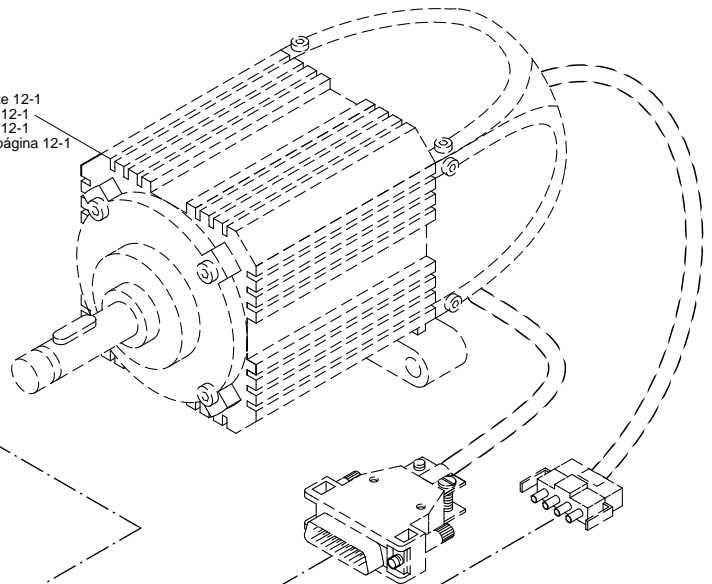

(220 V)

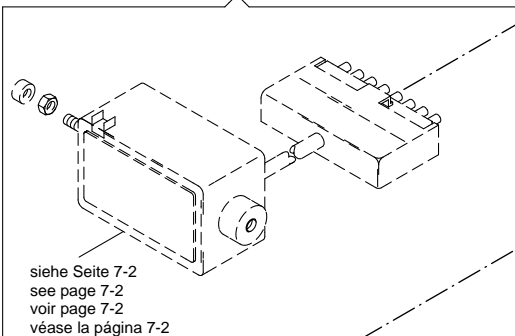

siehe Seite 7-2
see page 7-2
voir page 7-2
véase la página 7-2

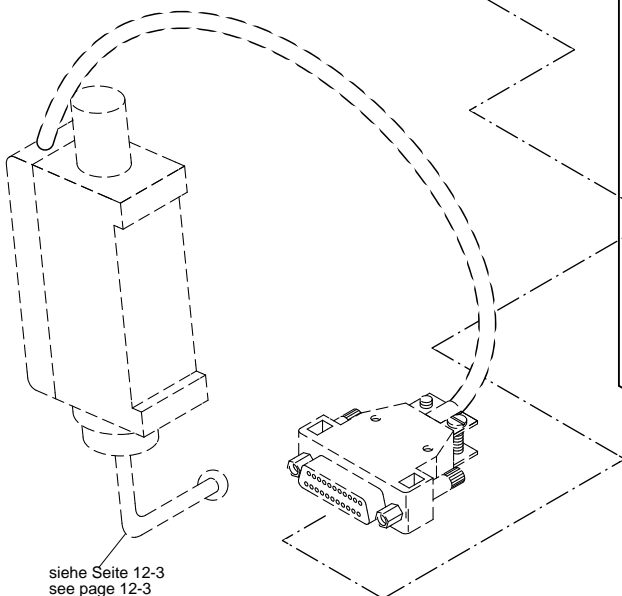
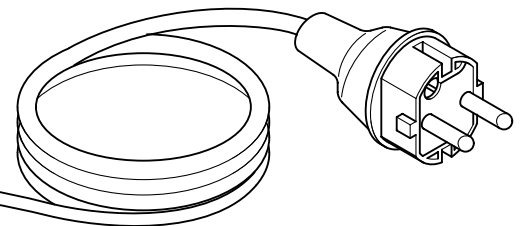

siehe Seite 12-3
see page 12-3
voir page 12-3
véase la página 12-3

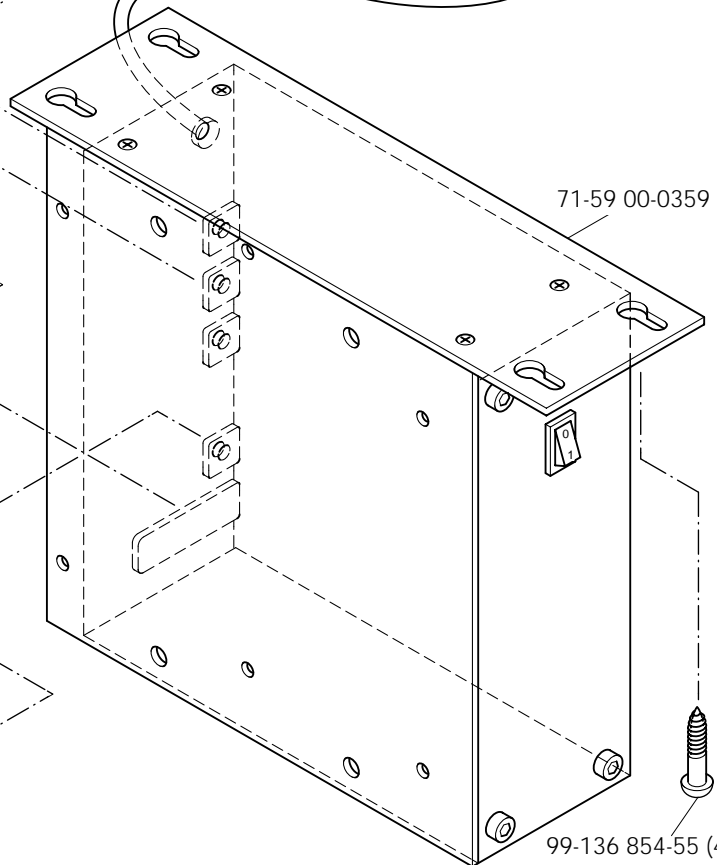

71-59 00-0359

99-136 854-55 (4x)

12.04

Steuerkasten

Control box

Boîtier de contrôle

Caja de mandos

PFAFF 1053-900/22

PFAFF 1183-900/22

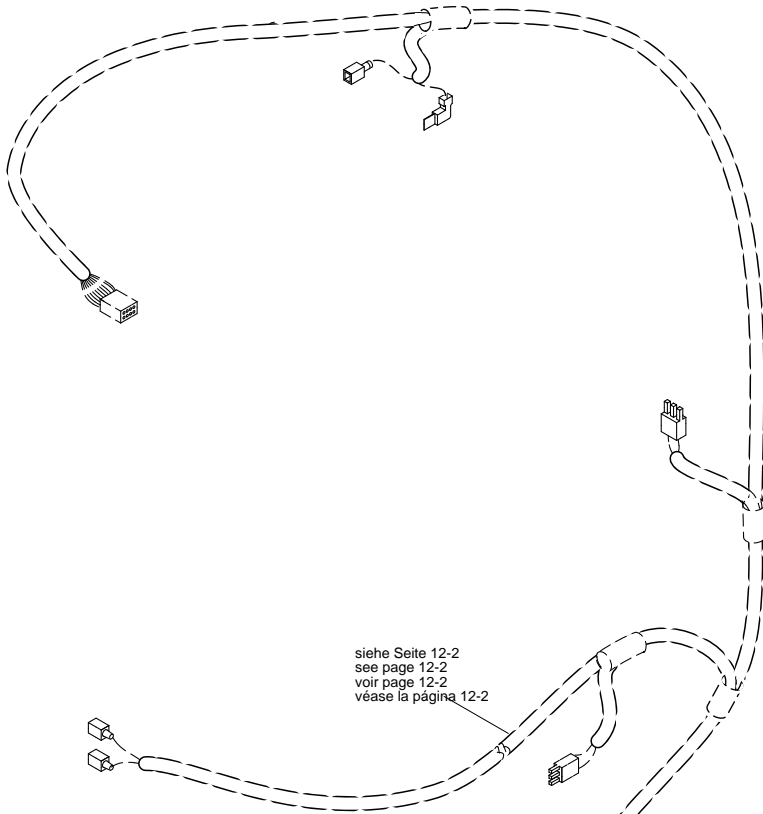
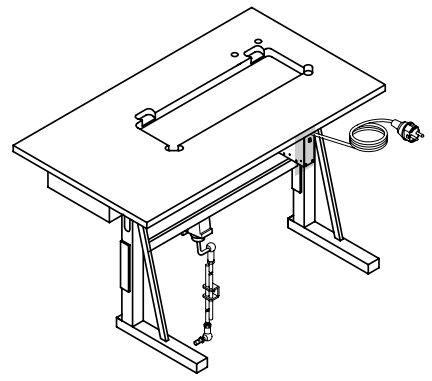

siehe Seite 12-2
see page 12-2
voir page 12-2
véase la página 12-2

siehe Seite 12-1
see page 12-1
voir page 12-1
véase la página 12-1

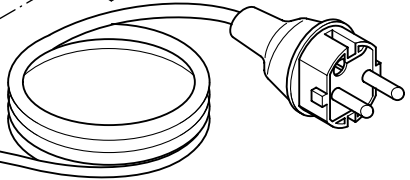
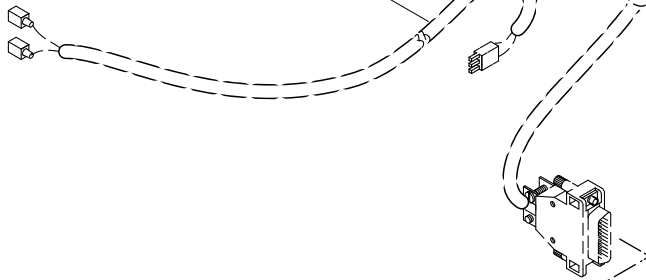
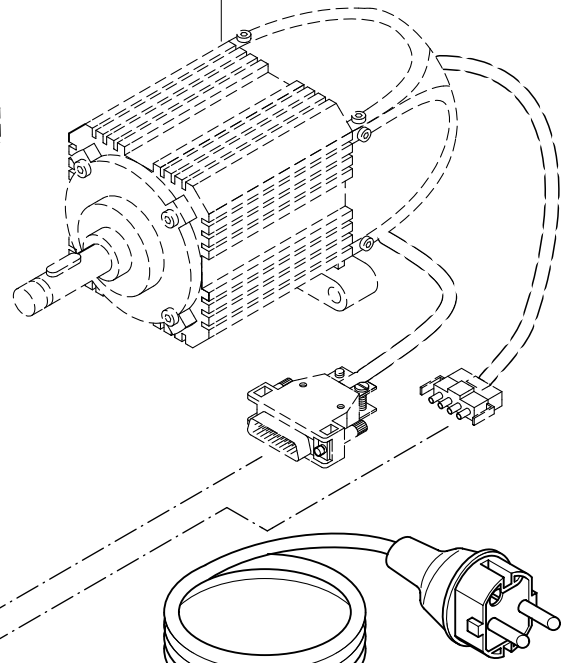

71-59 00-0722

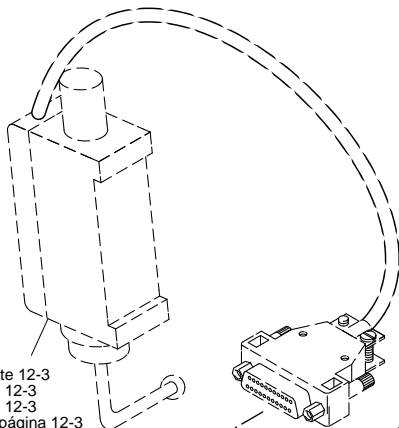

siehe Seite 12-3
see page 12-3
voir page 12-3
véase la página 12-3

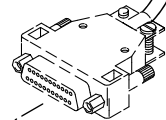

99-136 854-55 (4x)

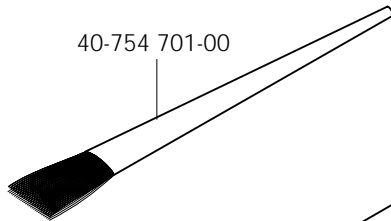
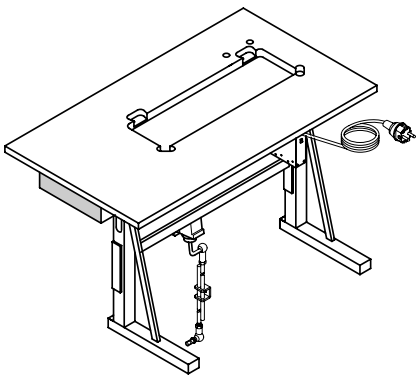

40-754 701-00

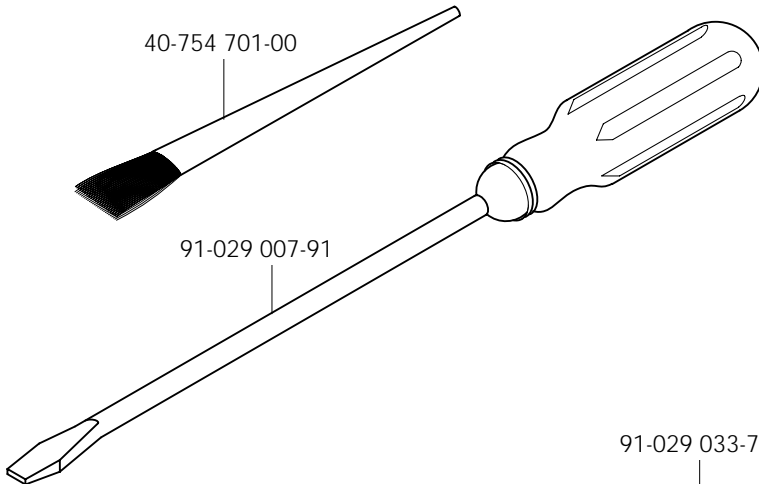

91-029 007-91

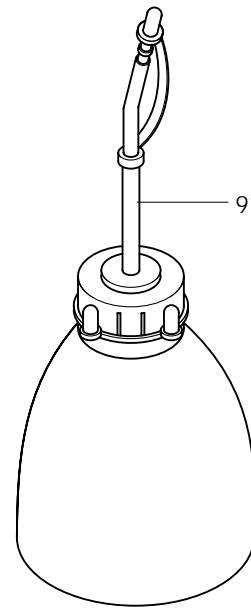

91-027 964-01

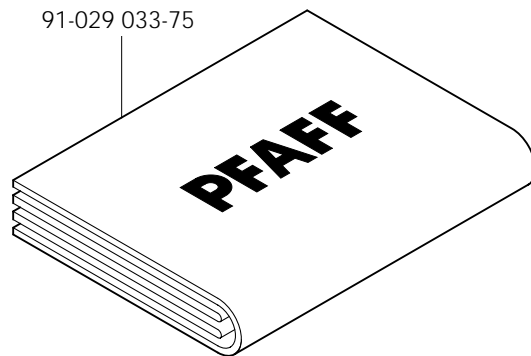



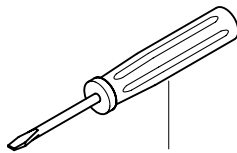

91-029 033-75

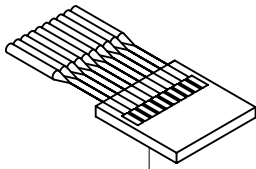

91-029 946-91

91-262 437-05



System DBx1 
 Systeme DBx1 
 Sistema DBx1 

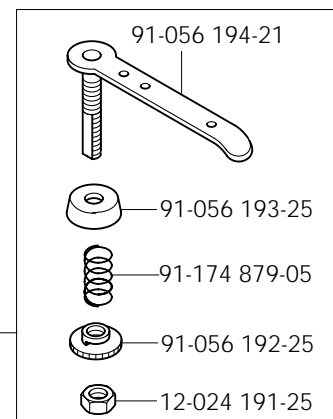

91-056 194-21

91-056 193-25

91-174 879-05

91-056 192-25

12-024 191-25

91-056 578-91

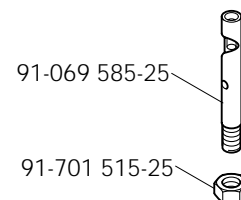

91-069 585-25

91-701 515-25

13.01

Zubehörteile
 Accessory parts
 Accessoires
 Accesorios

PFAFF 1053
 PFAFF 1183

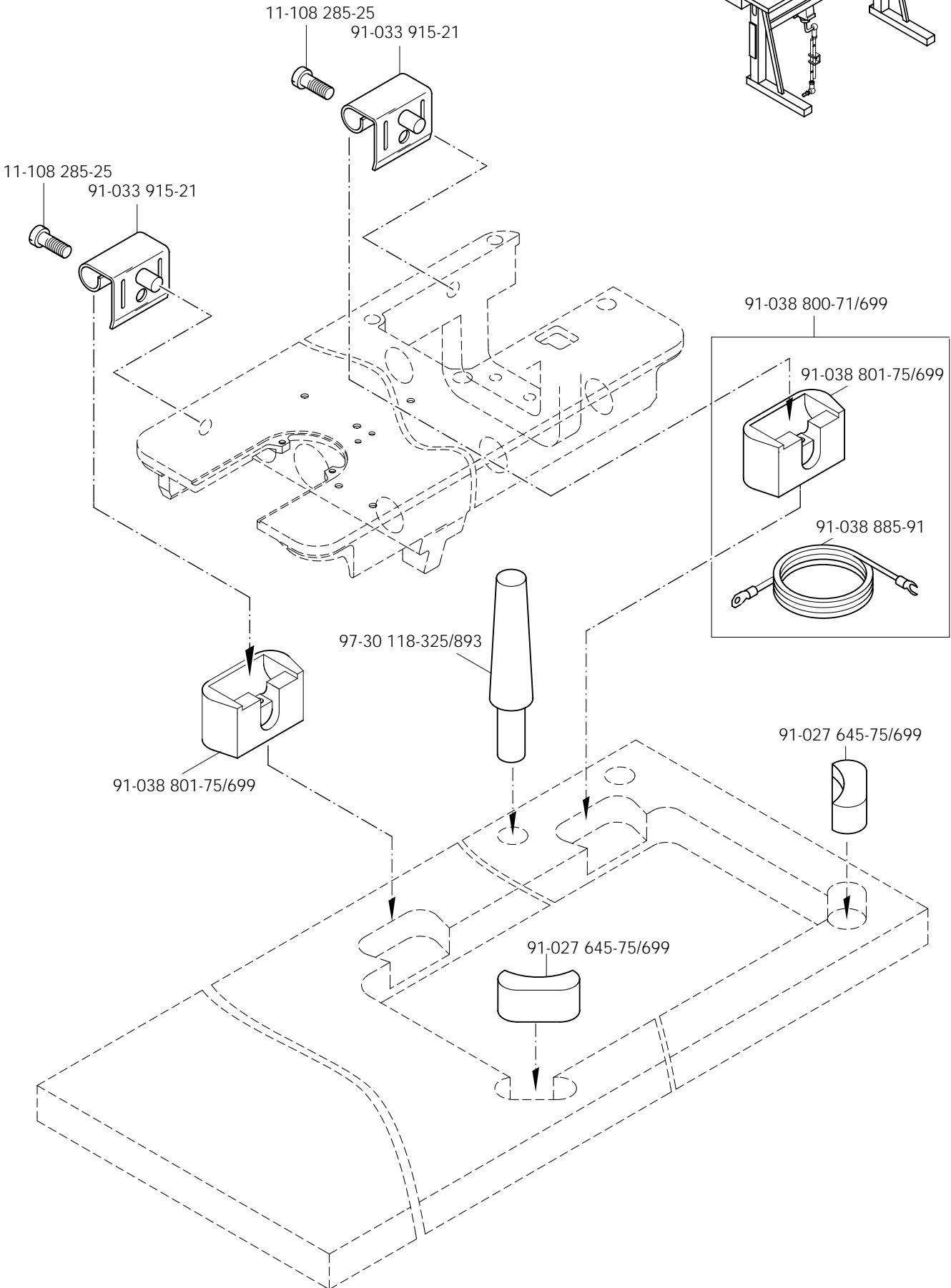
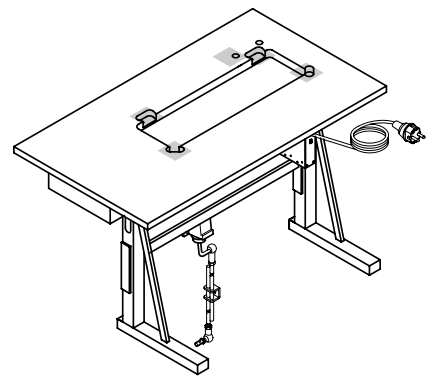

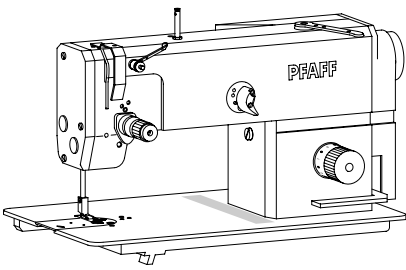

Knielüfterteile
 Knee lifter parts
 Pièces du releveur de genouillère
 Piezas del alzaprensatejas por rodillera

PFAFF 1053
 PFAFF 1183

13.02

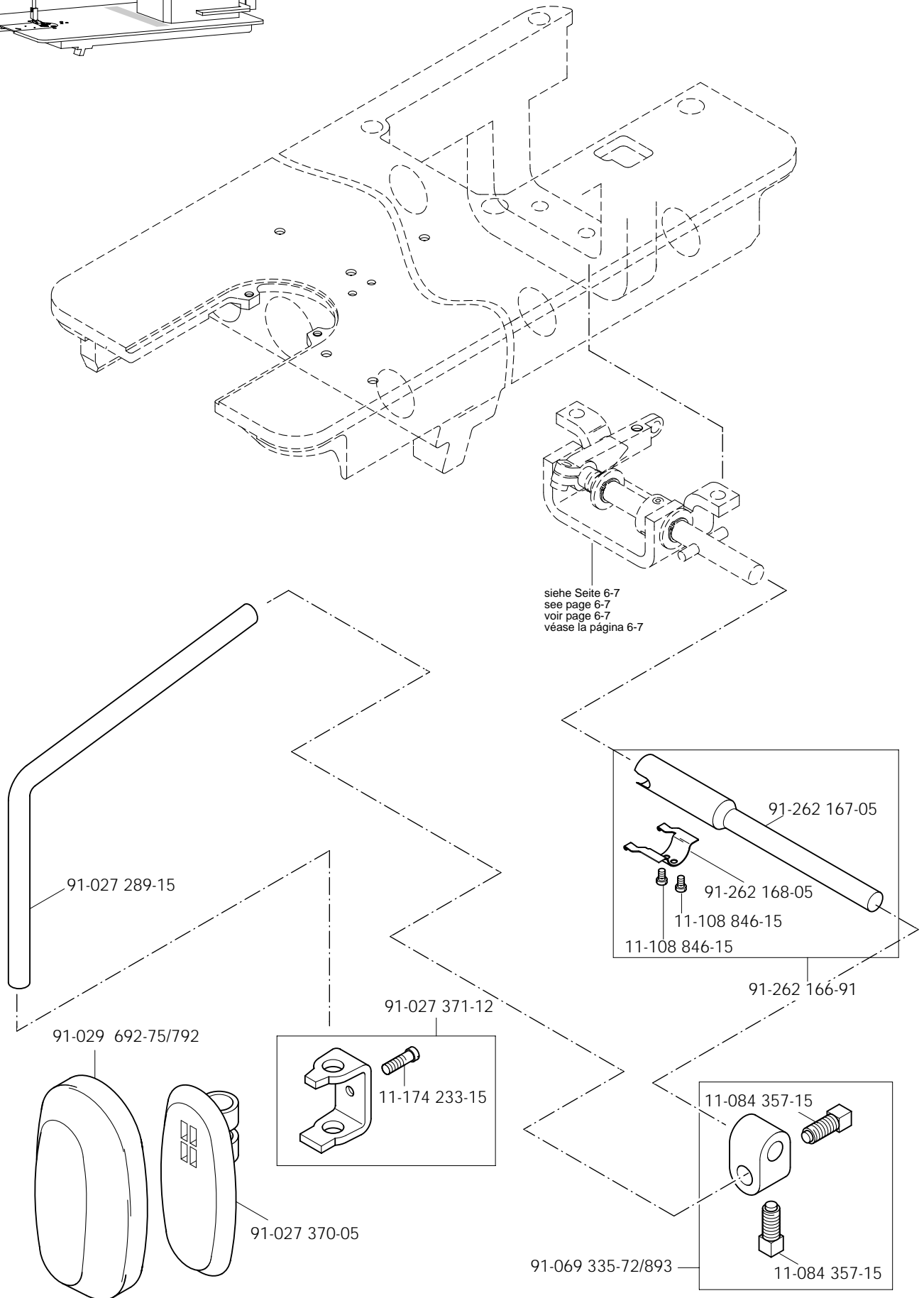

13.03

Garnrollenständer
 Reel stands
 Porte-bobines
 Portacarretes

PFAFF 1053
 PFAFF 1183

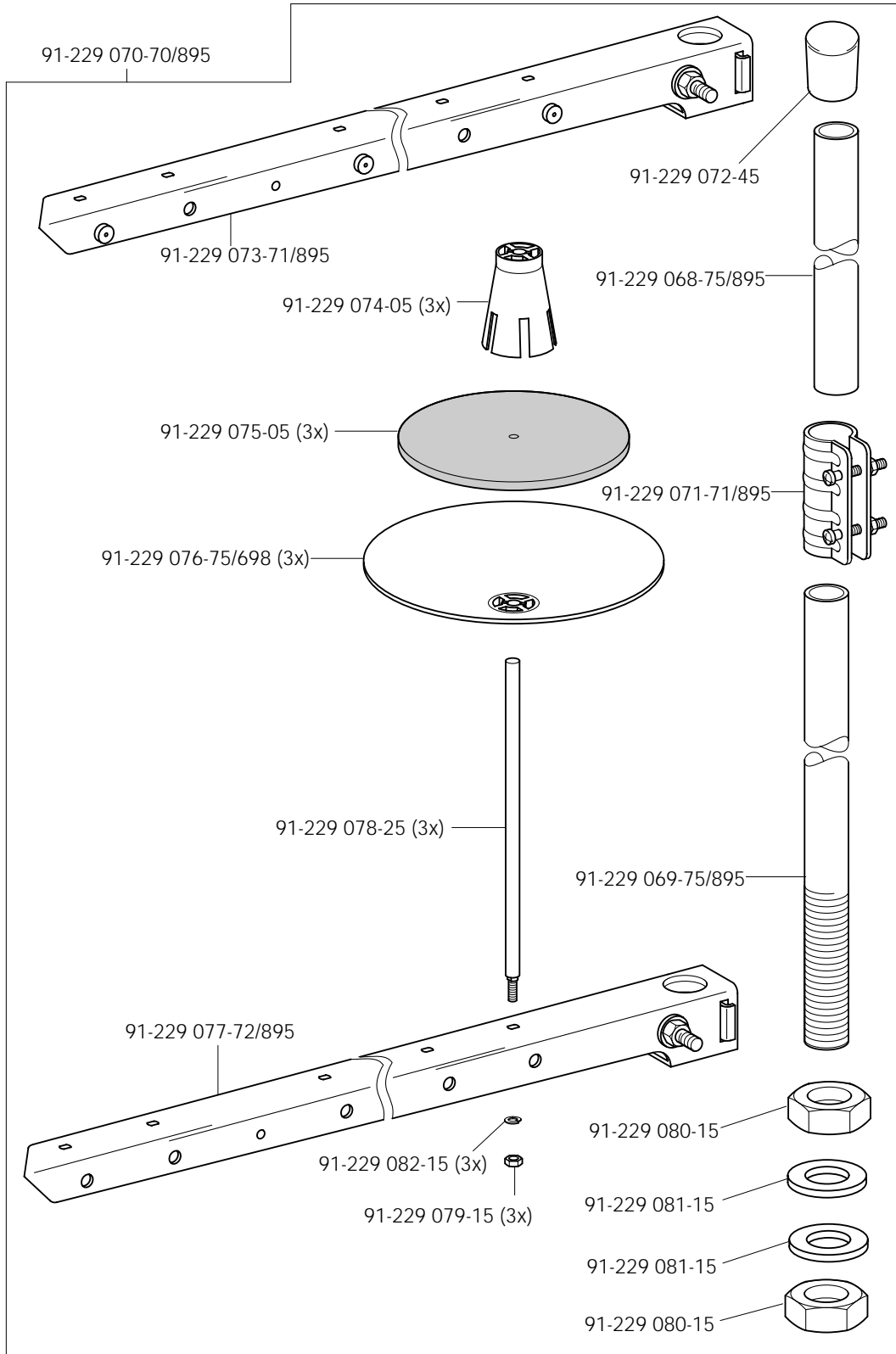
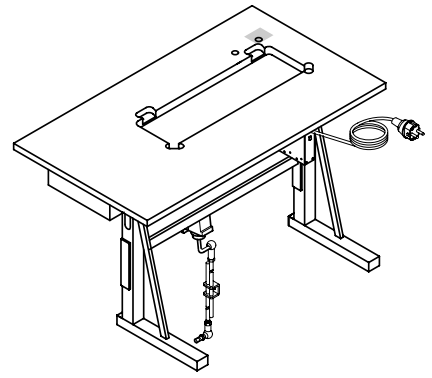

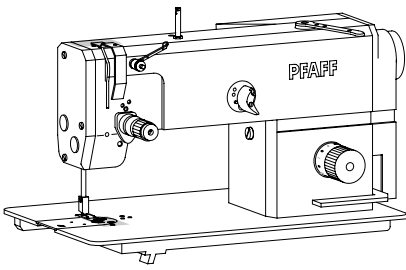

Einstellehren
Adjustment gauges
Calibres PFAFF 1053
Calibres de ajuste PFAFF 1183

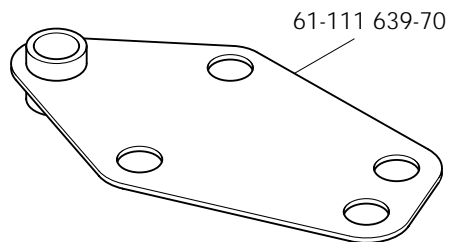
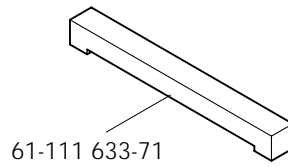
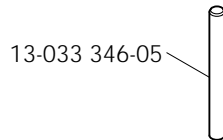

Öl Oil Huile Aceite	Mittelpunkts- Viskosität bei: Mean viscosity at: Viscosité moyenne à: Viscosidad media a:		Dichte bei: Density of: Densité à: Densidad a:		Bestellnummer für Behälter mit: Part number for can with: Numéro de commande pour récipients avec: Número de pedido para recipientes con:		
	°C	mm ² /s	°C	g/cm ³ (g/ml)	1 Liter 1 Litre 1 Litro	5 Liter 5 Litre 5 Litros	10 Liter 10 Litre 10 Litros
280-1-120 105	40	10,0	15	0,847	91-027 975-91	91-027 976-91	91-027 977-91

Fett Grease Graisse Grasa	Penetration Penetration Pénétration Penetración	Tropfpunkt Drip-point Point de suintement Punto de goteo	Bestellnummer für Behälter mit: Part number for can with: Numéro de commande pour récipients avec: Número de pedido para recipientes con:		
			mm/10	°C	0,25 kg
280-1-120 205					280-1-120 205
280-1-120 247	220-250	185			280-1-120 247

Reinigungsmittel Cleansing agent Agents de nettoyage Limpiadores			Bestellnummer für Behälter mit: Part number for can with: Numéro de commande pour récipients avec: Número de pedido para recipientes con:	
			240 ml	
95-665 735-91 Isopropyl-Alkohol			95-665 735-91	

Nähgeschwindigkeit max.. Stiche/min Maximum sewing speed in s.p.m. Nombre de points max./mn Número máx. de puntadas por minuto	Motordrehzahl U/min Motor speed in r.p.m. Régime moteur en tours/mn Régimen del motor en r.p.m.	Frequenz Frequency Fréquence Frecuencia	Handrad-Durchmesser ¹⁾ in mm Balance wheel diameter ¹⁾ in mm Diamètre du volant ¹⁾ en mm Diámetro del volante ¹⁾ en mm	Keilriemenscheiben-Durchmesser ¹⁾ in mm V-belt pulley diameter ¹⁾ in mm Diamètre de la poulie à gorge ¹⁾ en mm Diámetro de la polea para correa en "V" ¹⁾ en mm	Teilenummer der Keilriemenscheibe Part number of V-belt pulley Numéro de pièce des poulies à gorge en V N° de las piezas de poleas para correas en "V"
PFAFF 1053					
4000	2800	50 Hz	65	95	16-437 080-05
4000	3400	60 Hz	65	80	16-437 050-05
3800	2800	50 Hz	65	90	16-437 070-05
3800	3400	60 Hz	65	75	16-437 050-05
3500	2800	50 Hz	65	80	16-437 050-05
3500	3400	60 Hz	65	67	16-437 020-05
3000	1400	50 Hz	65	140	16-437 140-05
3000	1700	60 Hz	65	118	16-437 120-05
2300	1400	50 Hz	65	112	16-437 110-05
2300	1700	60 Hz	65	90	16-437 070-05

¹⁾ Wirksamer Durchmesser
 Effective diameter
 Diamètre effectif
 Diámetro efectivo

Nähgeschwindigkeit max.: Stiche/min Maximum sewing speed in s.p.m. Nombre de points max./mn Número máx. de puntadas por minuto	Motordrehzahl U/min Motor speed in r.p.m. Régime moteur en tours/mn Régimen del motor en r.p.m.	Frequenz Frequency Fréquence Frecuencia	Handrad-Durchmesser ¹⁾ in mm Balance wheel diameter ¹⁾ in mm Diamètre du volant ¹⁾ en mm Diámetro del volante ¹⁾ en mm	Keilriemenscheiben-Durchmesser ¹⁾ in mm V-belt pulley diameter ¹⁾ in mm Diamètre de la poulie à gorge ¹⁾ en mm Diámetro de la polea para correa en "V" ¹⁾ en mm	Teilenummer der Keilriemenscheibe Part number of V-belt pulley Numéro de pièce des poulies à gorge en V N° de las piezas de poleas para correas en "V"
PFAFF 1183					
5500	2800	50 Hz	65	132	16-437 901-05
5500	3400	60 Hz	65	106	16-437 100-05
5000	2800	50 Hz	65	118	16-437 120-05
5000	3400	60 Hz	65	95	16-437 080-05
4000	2800	50 Hz	65	95	16-437 080-05
4000	3400	60 Hz	65	80	16-437 050-05
3800	2800	50 Hz	65	90	16-437 070-05
3800	3400	60 Hz	65	75	16-437 040-05
3500	2800	50 Hz	65	80	16-437 050-05
3500	3400	60 Hz	65	67	16-437 020-05
3000	1400	50 Hz	65	140	16-437 140-05
3000	1700	60 Hz	65	118	16-437 120-05
2300	1400	50 Hz	65	112	16-437 110-05
2300	1700	60 Hz	65	90	16-437 070-05

No.	Seite Page Pages Página	No.	Seite Page Pages Página	No.	Seite Page Pages Página	No.	Seite Page Pages Página
11-022 293-15	12 - 3	11-130 581-15	6 - 7	11-330 955-15	6 - 4	12-610 210-45	4 - 2, 4 - 3
11-084 357-15	13 - 3	11-132 172-15	4 - 2, 4 - 3, 10 - 1	11-330 962-15	6 - 1	12-610 230-45	6 - 2, 6 - 3, 6 - 7, 7 - 4, 7 - 5, 7 - 9, 7 - 10
11-106 260-15	3 - 1	11-132 223-15	4 - 1	11-330 964-15	5 - 2, 6 - 4	12-610 250-45	6 - 4
11-108 084-15	7 - 4, 7 - 5, 7 - 9, 7 - 10	11-170 278-15	5 - 1	11-330 968-15	6 - 4	12-610 280-45	6 - 5
11-108 087-15	7 - 4, 7 - 5, 7 - 9, 7 - 10	11-173 168-25	4 - 2, 4 - 3	11-335 085-15	7 - 4, 7 - 5, 7 - 9, 7 - 10	12-618 120-45	7 - 2, 7 - 7
11-108 171-15	11 - 1	11-174 233-15	13 - 3	11-335 280-15	5 - 2, 5 - 6, 6 - 4	12-618 210-45	5 - 6
11-108 174-15	10 - 1, 12 - 3	11-178 223-25	5 - 5	11-341 277-15	4 - 1, 4 - 2, 4 - 3	12-624 200-45	7 - 1, 7 - 6
11-108 174-25	4 - 1	11-210 081-15	8 - 1	11-341 902-15	6 - 4	12-640 130-55	4 - 1, 5 - 3
11-108 177-15	6 - 6, 8 - 1	11-210 168-15	7 - 2, 7 - 7, 10 - 1	12-005 154-15	8 - 1	12-640 150-55	5 - 1, 5 - 5, 8 - 1
11-108 180-15	8 - 1	11-210 168-25	5 - 3	12-005 171-15	6 - 7	12-640 170-55	5 - 5
11-108 222-15	6 - 2, 6 - 3, 7 - 2, 7 - 4, 7 - 5, 7 - 7, 7 - 9, 7 - 10	11-210 178-15	8 - 1	12-005 195-15	8 - 1	12-640 200-55	4 - 1
11-108 222-25	3 - 1	11-210 265-15	5 - 2	12-024 151-15	7 - 2, 7 - 7	12-650 008-55	3 - 1
11-108 225-15	3 - 1, 6 - 4	11-225 220-15	4 - 2, 4 - 3	12-024 171-15	6 - 7	12-660 390-45	6 - 2, 6 - 3, 7 - 4, 7 - 5, 7 - 9, 7 - 10
11-108 228-25	3 - 1	11-225 232-15	4 - 1	12-024 191-15	7 - 3, 7 - 8, 12 - 3	12-710 230-12	6 - 7
11-108 285-25	13 - 2	11-250 084-25	5 - 3	12-024 191-25	5 - 3, 13 - 1	12-710 901-22	5 - 5
11-108 288-15	6 - 7	11-305 226-15	6 - 7	12-305 114-15	4 - 2, 4 - 3, 11 - 1	13-030 341-05	3 - 1
11-108 846-15	13 - 3	11-305 239-15	6 - 7	12-305 264-15	6 - 7	13-033 190-15	7 - 4, 7 - 5, 7 - 9, 7 - 10
11-130 101-15	8 - 1	11-317 950-15	6 - 1, 8 - 1	12-305 904-05	7 - 3, 7 - 8	13-033 208-05	5 - 4
11-130 113-15	7 - 3, 7 - 8	11-320 171-15	5 - 5	12-335 151-15	7 - 2, 7 - 7	13-033 346-05	14 - 1
11-130 167-15	8 - 1	11-330 166-15	7 - 3, 7 - 8	12-341 090-25	5 - 4	13-052 085-55	5 - 2
11-130 170-15	3 - 1	11-330 169-15	12 - 1	12-349 901-05	6 - 3, 7 - 5, 7 - 10	13-063 193-05	6 - 2, 6 - 3, 7 - 4, 7 - 5, 7 - 9, 7 - 10
11-130 176-15	4 - 2, 4 - 3, 6 - 1	11-330 175-15	4 - 1, 7 - 1, 7 - 6	12-360 023-05	8 - 1	13-064 247-05	4 - 1
11-130 194-15	3 - 1	11-330 205-15	12 - 3	12-360 063-05	5 - 4, 5 - 5	13-068 385-05	5 - 6
11-130 224-15	6 - 4, 6 - 7	11-330 220-15	4 - 1, 4 - 2, 4 - 3, 7 - 1, 7 - 6	12-360 064-05	4 - 2, 4 - 3	13-250 097-25	4 - 2, 4 - 3
11-130 284-15	6 - 1	11-330 277-15	5 - 2, 5 - 4, 5 - 5, 5 - 6, 6 - 2, 6 - 3, 6 - 5, 7 - 3, 7 - 4, 7 - 5, 7 - 8, 7 - 9, 7 - 10, 9 - 1	12-360 083-05	5 - 6	14-010 172-01	6 - 4
11-130 287-15	3 - 1, 6 - 5, 7 - 2, 7 - 7	11-330 280-15	5 - 2	12-500 150-45	12 - 3	14-016 080-01	6 - 2, 6 - 3, 7 - 4, 7 - 5, 7 - 9, 7 - 10
11-130 293-15	10 - 1	11-330 952-15	4 - 1, 5 - 4, 6 - 1, 6 - 2, 6 - 3, 6 - 4, 7 - 1, 7 - 4, 7 - 5, 7 - 6, 7 - 9, 7 - 10	12-518 150-45	7 - 3, 7 - 8	14-016 101-91	5 - 2
11-130 383-15	12 - 1			12-518 280-45	6 - 5	14-016 151-91	5 - 2
11-130 395-15	6 - 7			12-610 190-45	5 - 1, 6 - 1, 6 - 4, 6 - 5, 6 - 7, 7 - 2, 7 - 3, 7 - 7, 7 - 8	14-016 171-91	6 - 4
11-130 494-15	6 - 7					14-018 624-91	6 - 4
11-130 557-15	6 - 7						

No.	Seite Page Pages Página	No.	Seite Page Pages Página	No.	Seite Page Pages Página	No.	Seite Page Pages Página
14-215 013-03	6 - 4, 7 - 3, 7 - 8	71-59 00-0721	12 - 3	91-056 760-05	7 - 1, 7 - 6	91-118 937-05	5 - 3
14-215 031-03	4 - 2, 4 - 3	71-59 00-0722	12 - 5	91-069 056-05	4 - 2	91-118 939-21	5 - 3
14-215 121-13	6 - 5	91-008 034-05	10 - 1	91-069 075-01	4 - 1	91-118 940-05	5 - 3
14-602 901-01	5 - 3	91-009 035-25	4 - 1	91-069 079-72/895	4 - 1	91-130 865-15	8 - 1
14-650 243-05	4 - 1	91-021 124-15	8 - 1	91-069 105-25	4 - 2, 4 - 3	91-161 334-25	4 - 2, 4 - 3
15-120 008-05	12 - 1	91-027 289-15	13 - 3	91-069 322-01	4 - 1	91-162 578-71/698	3 - 1
15-120 013-05	7 - 2, 7 - 7	91-027 370-05	13 - 3	91-069 335-72/893	13 - 3	91-162 582-75/895	3 - 1
16-049 040-11	12 - 3	91-027 371-12	13 - 3	91-069 434-91	4 - 1	91-162 583-75/699	3 - 1
16-414 139-05	11 - 1	91-027 645-75/699	13 - 2	91-069 554-92	6 - 1	91-162 596-25	4 - 2, 4 - 3
16-437 020-05	16 - 1, 16 - 2	91-027 964-01	13 - 1	91-069 562-05	4 - 1	91-162 597-05	6 - 2, 6 - 3, 7 - 4, 7 - 5, 7 - 9, 7 - 10
16-437 040-05	16 - 2	91-027 975-91	15 - 1	91-069 568-05	4 - 1	91-162 690-92	4 - 1
16-437 050-05	16 - 1, 16 - 2	91-027 976-91	15 - 1	91-069 579-05	4 - 1	91-162 694-05	4 - 1
16-437 070-05	16 - 1, 16 - 2	91-027 977-91	15 - 1	91-069 585-25	5 - 3, 13 - 1	91-162 920-92	6 - 2, 6 - 3, 7 - 4, 7 - 5, 7 - 9, 7 - 10
16-437 080-05	16 - 1, 16 - 2	91-028 036-25	7 - 2, 7 - 7	91-088 881-11	8 - 1	91-162 921-92	6 - 4
16-437 100-05	16 - 2	91-029 007-91	13 - 1	91-088 883-11	8 - 1	91-165 685-05	7 - 4, 7 - 5, 7 - 9, 7 - 10
16-437 110-05	16 - 1, 16 - 2	91-029 033-75	13 - 1	91-100 117-15	4 - 1	91-165 939-71/698	10 - 1
16-437 120-05	16 - 1, 16 - 2	91-029 692-75/792	13 - 3	91-100 270-25	5 - 4	91-167 590-15	3 - 1
16-437 140-05	16 - 1, 16 - 2	91-029 946-91	13 - 1	91-100 281-25	5 - 3	91-167 750-05	10 - 1
16-437 901-05	16 - 2	91-031 888-15	12 - 3	91-100 331-15	5 - 1	91-168 024-07	5 - 4, 5 - 5
16-479 081-05	7 - 1, 7 - 6	91-032 837-15	12 - 3	91-100 400-15	5 - 2	91-168 025-05	4 - 2, 4 - 3
40-754 701-00	13 - 1	91-032 851-11	12 - 3	91-105 482-05	5 - 4	91-168 341-07	5 - 6
61-111 633-71	14 - 1	91-033 765-15	6 - 5	91-118 098-25	5 - 3	91-168 347-05	6 - 5
61-111 639-70	14 - 1	91-033 915-21	13 - 2	91-118 099-91	5 - 3	91-168 480-15	5 - 2
71-11 00-0335	8 - 1	91-038 800-71/699	13 - 2	91-118 570-92	5 - 2	91-168 833-07	6 - 5
71-16 00-0891	7 - 2	91-038 801-75/699	13 - 2	91-118 681-05	5 - 3	91-169 556-05	6 - 1, 6 - 4, 7 - 3, 7 - 8
71-17 00-0213	7 - 2	91-038 885-91	13 - 2	91-118 682-05	5 - 3	91-171 042-05	5 - 3
71-17 00-0214	9 - 1	91-056 192-25	5 - 3, 7 - 1, 7 - 6, 13 - 1	91-118 683-05	5 - 3	91-171 049-05	5 - 3
71-17 00-0215	7 - 7	91-056 193-25	5 - 3, 7 - 1, 7 - 6, 13 - 1	91-118 685-05	5 - 3	91-171 050-05	4 - 1
71-17 00-0216	8 - 1	91-056 194-21	5 - 3, 13 - 1	91-118 711-05	6 - 1	91-171 068-05	4 - 1
71-17 00-0217	10 - 1	91-056 197-91	7 - 1, 7 - 6	91-118 931-05	5 - 3	91-171 158-92	6 - 4
71-52 35-5541	12 - 1	91-056 198-21	7 - 1, 7 - 6	91-118 934-91	5 - 3	91-171 205-07	6 - 5
71-59 00-0359	12 - 4	91-056 578-91	5 - 3, 13 - 1	91-118 935-05	5 - 3		

No.	Seite Page Pages Página	No.	Seite Page Pages Página	No.	Seite Page Pages Página	No.	Seite Page Pages Página
91-171 229-05	6 - 4	91-229 078-25	13 - 4	91-262 144-05	7 - 1, 7 - 6	91-262 187-15	6 - 2, 6 - 3, 7 - 4, 7 - 5, 7 - 9, 7 - 10
91-171 409-12	6 - 5	91-229 079-15	13 - 4	91-262 145-05	7 - 1, 7 - 6	91-262 188-15	7 - 4, 7 - 5, 7 - 9, 7 - 10
91-171 785-05	7 - 5, 7 - 10	91-229 080-15	13 - 4	91-262 146-91	7 - 3, 7 - 8	91-262 189-91	7 - 4, 7 - 5, 7 - 9, 7 - 10
91-171 811-05	5 - 1	91-229 081-15	13 - 4	91-262 147-91	7 - 3, 7 - 8	91-262 190-91	7 - 5, 7 - 10
91-171 853-15	7 - 4, 7 - 5, 7 - 9, 7 - 10	91-229 082-15	13 - 4	91-262 148-05	7 - 1, 7 - 6	91-262 193-12	5 - 1
91-173 967-15	8 - 1	91-262 060-91	7 - 1, 7 - 6	91-262 149-05	7 - 3, 7 - 8	91-262 194-92	12 - 1
91-173 968-15	8 - 1	91-262 061-05	6 - 4	91-262 150-91	6 - 4	91-262 195-92	6 - 4
91-174 016-05	4 - 2, 4 - 3	91-262 062-92	6 - 4	91-262 151-05	6 - 4	91-262 196-05	5 - 2
91-174 223-05	8 - 1	91-262 063-05	7 - 2, 7 - 7	91-262 152-05	6 - 4	91-262 197-05	5 - 2
91-174 474-25	3 - 1, 8 - 1	91-262 064-05	7 - 3, 7 - 8	91-262 153-92	6 - 4	91-262 199-71/698	5 - 4
91-174 783-05	5 - 3	91-262 065-05	7 - 3, 7 - 8	91-262 154-92	6 - 4	91-262 200-01	5 - 4
91-174 851-05	7 - 1, 7 - 6	91-262 067-01	7 - 3, 7 - 8	91-262 155-92	6 - 4	91-262 201-05	5 - 4
91-174 860-05	7 - 2, 7 - 7	91-262 069-05	7 - 3, 7 - 8	91-262 156-91	6 - 5	91-262 202-05	5 - 4
91-174 861-05	7 - 2, 7 - 7	91-262 073-91	4 - 2, 4 - 3	91-262 157-05	6 - 5	91-262 203-05	5 - 4
91-174 879-05	5 - 3, 13 - 1	91-262 077-05	4 - 2, 4 - 3	91-262 158-05	6 - 5	91-262 204-75/698	5 - 4
91-175 203-05	6 - 5	91-262 078-01	4 - 2, 4 - 3	91-262 161-72/698	5 - 2	91-262 205-05	5 - 4
91-175 265-12	8 - 1	91-262 080-05	4 - 2, 4 - 3	91-262 162-75/698	3 - 1	91-262 206-05	5 - 4
91-175 354-15	8 - 1	91-262 082-92	4 - 2, 4 - 3	91-262 163-05	6 - 7	91-262 207-92	5 - 4
91-175 557-01	7 - 1, 7 - 6	91-262 083-01	5 - 2	91-262 164-02	6 - 7	91-262 208-05	7 - 4, 7 - 5, 7 - 9, 7 - 10
91-175 729-15	8 - 1	91-262 083-92	5 - 2	91-262 166-91	13 - 3	91-262 209-91	7 - 5, 7 - 10
91-175 732-15	8 - 1	91-262 086-05	4 - 2, 4 - 3	91-262 167-05	13 - 3	91-262 210-92	5 - 5
91-175 806-91	8 - 1	91-262 107-25	10 - 1	91-262 168-05	13 - 3	91-262 214-05	6 - 2, 6 - 3, 7 - 4, 7 - 5, 7 - 9, 7 - 10
91-229 068-75/895	13 - 4	91-262 109-71/895	3 - 1	91-262 170-05	6 - 7	91-262 215-91	7 - 5, 7 - 10
91-229 069-75/895	13 - 4	91-262 133-91	7 - 2, 7 - 7	91-262 172-92	6 - 7	91-262 218-05	5 - 5
91-229 070-70/895	13 - 4	91-262 134-01	7 - 2, 7 - 7	91-262 174-01	5 - 1	91-262 219-91	5 - 5
91-229 071-71/895	13 - 4	91-262 136-05	7 - 3, 7 - 8	91-262 175-01	5 - 1	91-262 222-05	5 - 5
91-229 072-45	13 - 4	91-262 137-05	7 - 3, 7 - 8	91-262 179-05	5 - 1	91-262 225-91	7 - 4, 7 - 5, 7 - 9, 7 - 10
91-229 073-71/895	13 - 4	91-262 138-05	7 - 3, 7 - 8	91-262 181-05	5 - 1	91-262 226-91	6 - 2, 6 - 3, 7 - 4, 7 - 5, 7 - 9, 7 - 10
91-229 074-05	13 - 4	91-262 139-01	7 - 3, 7 - 8	91-262 183-75/895	3 - 1	91-262 228-01	6 - 6
91-229 075-45	13 - 4	91-262 141-91	7 - 2	91-262 184-05	7 - 4, 7 - 5, 7 - 9, 7 - 10	91-262 231-72/893	5 - 6
91-229 076-75/698	13 - 4	91-262 142-05	3 - 1, 7 - 2, 7 - 7	91-262 185-05	7 - 4, 7 - 5, 7 - 9, 7 - 10	91-262 232-01	5 - 6
91-229 077-72/895	13 - 4	91-262 143-05	7 - 2, 7 - 7				

No.	Seite Page Pages Página	No.	Seite Page Pages Página	No.	Seite Page Pages Página	No.	Seite Page Pages Página
91-262 235-15	7 - 4, 7 - 5, 7 - 9, 7 - 10	91-262 377-91	6 - 2, 6 - 3	99-133 259-25	7 - 1, 7 - 6		
91-262 236-91	6 - 3	91-262 385-75/893	12 - 3	99-136 854-55	12 - 3, 12 - 4, 12 - 5		
91-262 237-91	6 - 3	91-262 415-91	7 - 4, 7 - 9	99-137 186-05	6 - 2, 6 - 3		
91-262 244-92	6 - 5	91-262 416-91	7 - 4, 7 - 9	99-137 187-15	6 - 2, 6 - 3		
91-262 245-04	6 - 5	91-262 417-91	6 - 2	99-137 188-15	6 - 3		
91-262 248-91	6 - 7	91-262 418-91	6 - 2	99-137 189-05	6 - 2, 6 - 3		
91-262 250-91	6 - 3	91-262 421-91	4 - 2	99-137 190-05	6 - 2, 6 - 3		
91-262 273-05	10 - 1	91-262 422-05	4 - 2	99-137 191-05	6 - 2, 6 - 3		
91-262 274-05	5 - 6	91-262 428-05	7 - 1, 7 - 6	99-137 192-05	6 - 2, 6 - 3		
91-262 277-05	6 - 1	91-262 429-05	7 - 2, 7 - 7	99-137 193-05	6 - 2, 6 - 3		
91-262 278-11	5 - 5	91-262 437-05	6 - 2, 6 - 3, 13 - 1	99-137 194-05	6 - 2, 6 - 3		
91-262 300-91	6 - 1	91-262 438-01	6 - 2	99-137 196-05	12 - 3		
91-262 301-12	6 - 1	91-262 440-71/895	8 - 1	280-1-120 205	15 - 1		
91-262 314-91	6 - 1	91-262 441-75/895	8 - 1	280-1-120 247	15 - 1		
91-262 315-96	6 - 1	91-262 443-91	7 - 7	25 161-8.014-9	4 - 3, 6 - 3, 7 - 5, 7 - 10		
91-262 320-91	4 - 3	91-262 442-75/895	8 - 1	25 161-8.015-2	4 - 3		
91-262 325-91	7 - 1, 7 - 6	91-262 446-05	9 - 1	25 161-8.015-9	6 - 3, 7 - 5, 7 - 10		
91-262 326-05	3 - 1	91-262 447-05	9 - 1	25 308-8.206-0	5 - 6		
91-262 329-75/895	3 - 1	91-262 457-12	4 - 1	26 536-3.010-9	4 - 2, 4 - 3, 6 - 3, 7 - 5, 7 - 10		
91-262 330-05	7 - 3, 7 - 8	91-262 460-15	8 - 1	S-000 691-000-001	6 - 1		
91-262 331-91	6 - 2, 6 - 3	91-262 461-15	8 - 1	S-281 816-452-435	4 - 1		
91-262 335-05	3 - 1	91-265 065-05	7 - 5, 7 - 10	S-504 051-000-001	6 - 1		
91-262 354-05	4 - 2, 4 - 3	91-265 189-05	6 - 1	S-504 112-000-001	4 - 2, 4 - 3		
91-262 355-92	5 - 4	91-265 198-15	5 - 1	S-505 317-459-435	6 - 1		
91-262 357-75/698	11 - 1	91-268 076-15	6 - 3, 7 - 5, 7 - 10				
91-262 360-05	6 - 2, 6 - 3, 7 - 4, 7 - 5, 7 - 9, 7 - 10	91-700 785-15	6 - 5				
91-262 364-91	7 - 1, 7 - 6	91-701 515-25	5 - 3, 13 - 1				
91-262 367-91	4 - 2, 4 - 3	95-600 649-05	8 - 1				
91-262 369-91	10 - 1	95-665 735-91	15 - 1				
91-262 370-15	10 - 1	95-669 358-05	6 - 3, 7 - 5, 7 - 10				
91-262 372-92	10 - 1	95-784 300-91	12 - 2				
91-262 376-91	6 - 3	97-30 118-325/893	13 - 2				

PFAFF

1053

1183

Unterklassen-Ausstattung

Subclass parts

Composition des sous-classes

Composición de las subclases

Unterklasse Subclass Sous-classe Subclase	-8/31 (-900/..)	-8/33 (-900/..)
Arbeitsgang Operation Opération Operación	Universalteilesatz, zum Nähen feiner Materialien. Universal part set for sewing light-weight materials. Jeu de pièces universel, pour matières fines. Juego de piezas universal, para materiales finos.	Universalteilesatz, zum Nähen für mittlere bis mittelschwere Materialien. Universal part set for sewing for medium-weight materials to medium-heavy materials. Jeu de pièces universel, pour matières moyennes à matières mi-lourdes. Juego de piezas universal, para materiales semifinos hasta de materiales semipesados.
Nadelstange Needle bar Barre à aiguille Barra de aguja	91-262 367-01 	91-262 367-01 
Nähfuß Presser foot Pied presseur Pie prensatelas	S-505 643-458-435	S-543 419-458-435
Stichplatte Needle plate Plaque à aiguille Placa de aguja	S-414 464-452-435	S-012 482-452-435
Stoffschieber Feed dog Griffe Transportador inferior	S-376 445-000-435	S-012 481-000-435
Schieber Slide Glissère Corredera	S-505 317-459-435	S-505 317-459-435



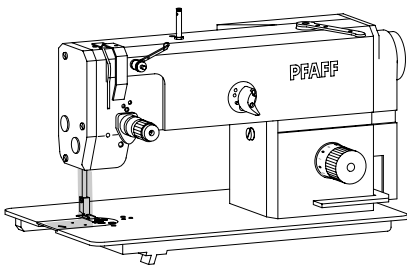





Nähwerkzeuge
 Gauge parts
 Organes de couture PFAFF 1053
 Organos de costura PFAFF 1183

18.02

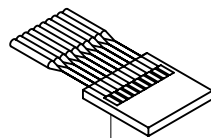
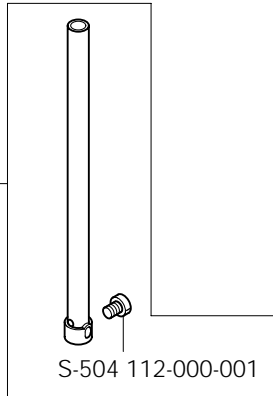
Unterklasse
 Subclass -8/31 (900/..)
 Sous-classe
 Subclase

91-262 367-91



System DBx1 
 Système DBx1 
 Sistema DBx1 

91-202 099-91

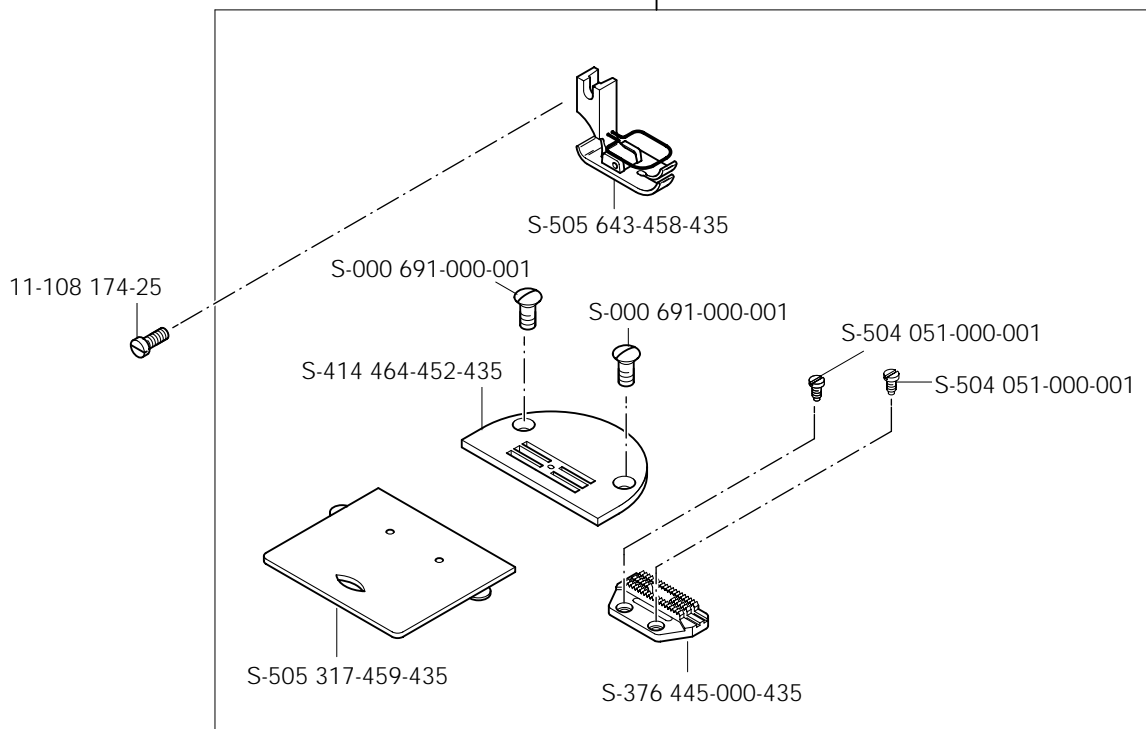

18.03

Nähwerkzeuge
 Gauge parts
 Organes de couture PFAFF 1053
 Organos de costura PFAFF 1183

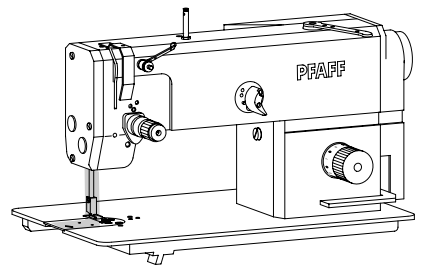

Unterklasse
 Subclass -8/33 (900/..)
 Sous-classe
 Subclase

91-262 367-91

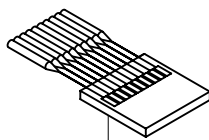
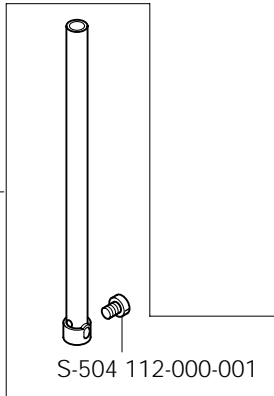

System DBx1
 Système DBx1
 Sistema DBx1

91-202 100-91

11-108 174-25

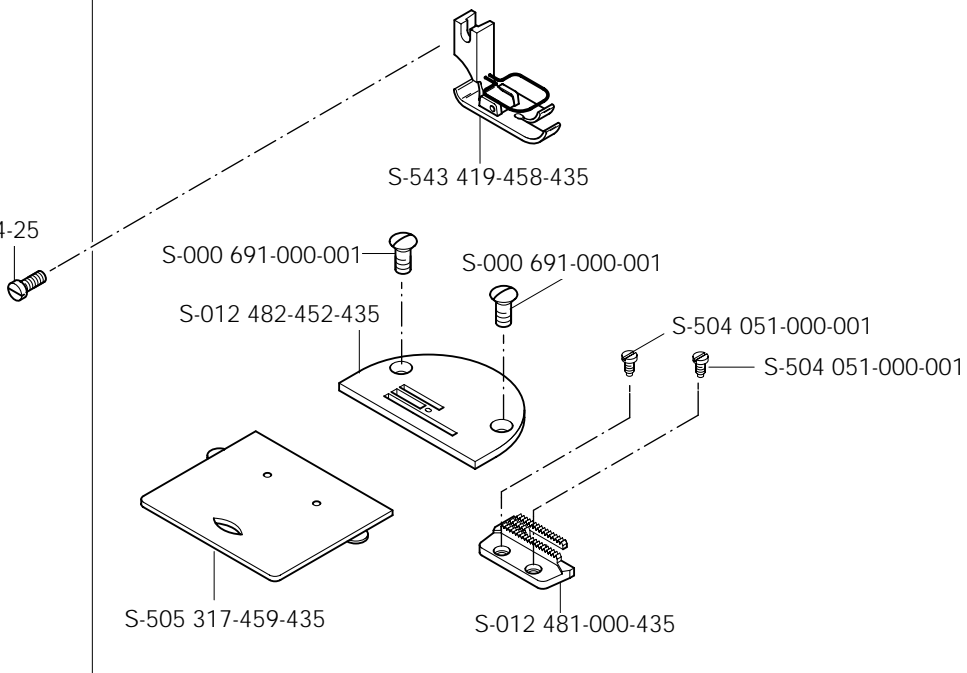

PFAFF

G.M. PFAFF
Aktiengesellschaft

Postfach 3020
D-67653 Kaiserslautern

Königstr. 154
D-67655 Kaiserslautern

Telefon: (0631) 200-0
Telefax: (0631) 172 02
Telex: 45753 PFAFF D

Gedruckt in der BRD
Printed in Germany
Imprimé en R.F.A.
Impreso en la R.F.A.

PFAFF