

目录

CONTENTS

1. 机头、外装部件	1
FRAME & MISCELLANEOUS COVER COMPONENTS	
2. 上轴、针杆部件	3
MAIN SHAFT & NEEDLE BAR COMPONENTS	
3. 中压脚部件(1)	5
PRESSER MECHANISM & PRESSER VARIABLE COMPONENTS (1)	
4. 中压脚部件(2)	7
PRESSER MECHANISM & PRESSER VARIABLE COMPONENTS (2)	
5. 辅助压脚、记号笔部件	9
AUXILIARY PRESSER MECHANISM & MARKER PEN COMPONENTS	
6. 松线部件	11
TENSION RELEASE & THREAD TENSION COMPONENTS	
7. 拨线部件	13
WIPER MECHANISM COMPONENTS	
8. 下轴剪线部件	15
LOWER SHAFT TRIM THREAD COMPONENTS	
9. 润滑部件	17
LUBRICATION COMPONENTS	
10. X-Y送料部件(1)	19
FEEDING COMPONENTS(1)	
11. X-Y送料部件(2)	21
FEEDING COMPONENTS(2)	
12. 气动部件	23
PNEUMATIC COMPONENTS	
13. 大缝台部件	25
BIG SEWING BED COMPONENTS	
14. 机架部件	27
MACHINE STAND COMPONENTS	
15. 附件部件	29
ACCESSORIES COMPONENTS	

1. 机头、外装部件

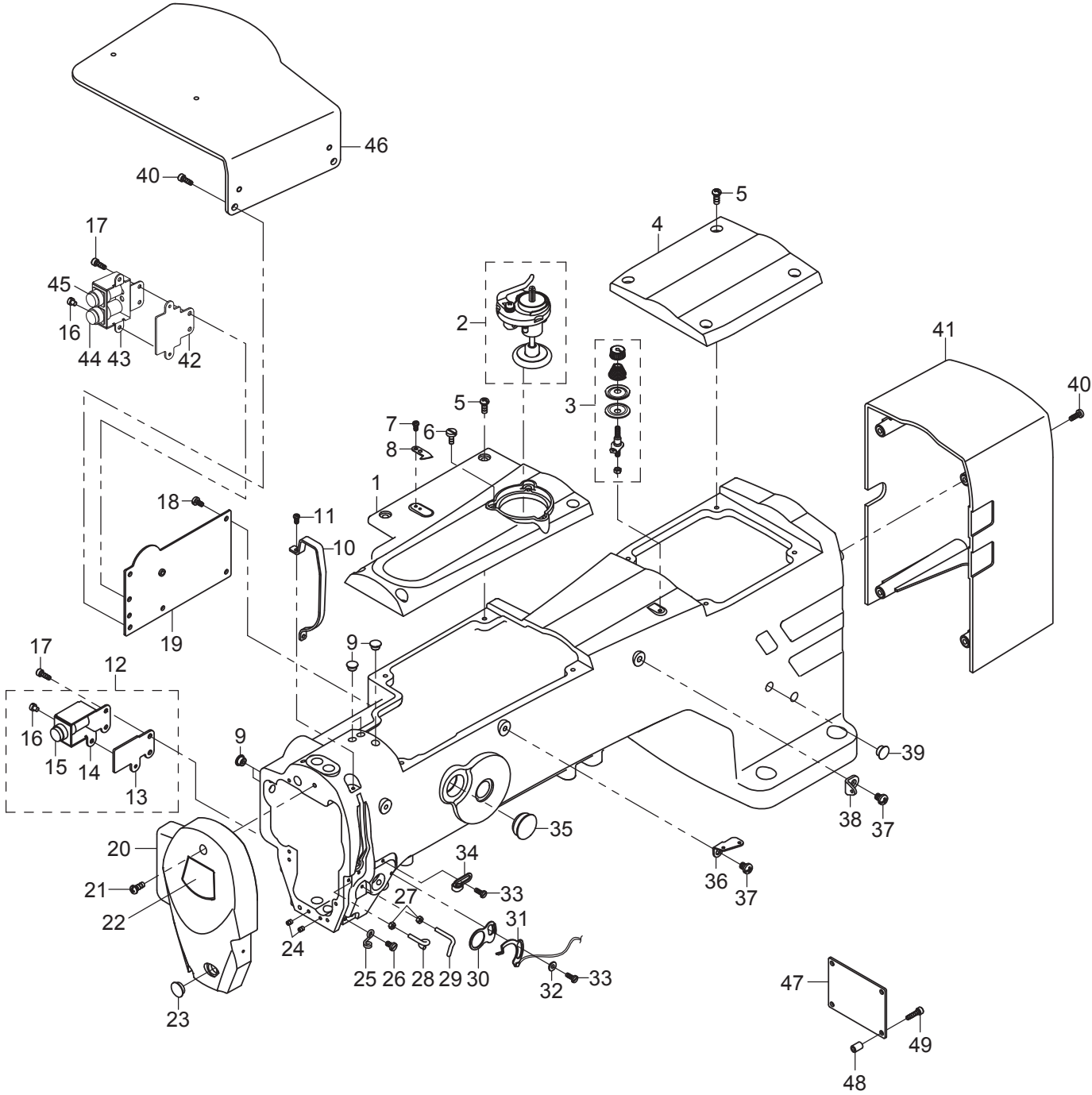

机头、外装部件

FRAME & MISCELLANEOUS COVER COMPONENTS

序号 No.	件号 Part No.	名称	DESCRIPTION	数量 Qty
1	20010035	上前盖	TOP_COVER_FRONT	1
2	10027383	绕线器	BOBBIN_WINDER_UNIT	1
3	10011134	绕线夹线器	BOBBIN_THREAD_TENSION_ASM	1
4	20010036	上后盖	TOP_COVER_REAR	1
5	10008776	螺钉 M5 L=12	SCREW M5 L=12	9
6	10011101	螺钉 SM11/64"×40 L=11	SCREW SM11/64"×40 L=11	3
7	10011143	螺钉 SM9/64"×40 L=7	SCREW SM9/64"×40 L=7	2
8	10011149	绕线切刀	THREAD_CUTTER	1
9	10000090	摆动架销油塞	RUBBER_PLUG	5
10	20003790	挑线杆防护罩	THREAD_TAKE_UP_LEVER_COVER	1
11	10011143	螺钉 SM9/64"×40 L=7	SCREW SM9/64"×40 L=7	2
12	20010744	急停开关组件	STOP_SWITCH_ASM	(1)
13	20010435	急停开关安装板喷漆件	STOP_SWITCH_PLATE	1
14	20010434	急停开关盒喷漆件	STOP_SWITCH_BOX	1
15	10028708	急停开关	STOP_SWITCH	1
16	10009595	螺钉 M4 L=4.5	SCREW M4 L=4.5	5
17	10000863	螺钉 M4 L=12	SCREW M4 L=12	4
18	10009868	螺钉 M4 L=8	SCREW M4 L=8	2
19	20013334	运模车后盖板	LEFTWARD_COVER	1
20	20008483	面板	FACE_COVER	1
21	10008776	螺钉 M5 L=12	SCREW M5 L=12	2
22	10005468	面板装饰牌	FACE_PLATE	1
23	10011099	橡胶塞	RUBBER_PLUG	1
24	10000563	螺钉 M4 L=5	SCREW M4 L=5	2
25	10011139	下线钩	ARM_THREAD_GUIDE_B	1
26	10010668	螺钉 SM11/64"×40 L=7.8	SCREW SM11/64"×40 L=7.8	1
27	10011140	螺母 SM9/64"×40	NUT SM9/64"×40	2
28	10011148	中线钩	ARM_THREAD_GUIDE_M	1
29	10000181	中线钩	L_SHAPED_THREAD_GUIDE	1
30	10000741	传感片内绝缘片	GUIDE_PLATE	1
31	20005462	断线检测组件	THB_SENSOR_CABLE_ASM	1
32	10000752	传感片外绝缘片	BUSHING	1
33	10009691	螺钉 SM9/64"×40 L=10	SCREW SM9/64"×40 L=10	2
34	10008940	右线钩	ARM_THREAD_GUIDE_R	1
35	10027270	橡胶塞	RUBBER_PLUG	1
36	10011200	上过线板	THREAD_GUIDE_PLATE_B	1
37	10011158	螺钉 SM15/64"×28 L=7	SCREW SM15/64"×28 L=7	2
38	10011145	单眼过线板	THREAD_GUIDE_PLATE_A	1
39	10011136	橡胶塞	RUBBER_PLUG	2
40	10003049	螺钉 M4 L=12	SCREW M4 L=12	6
41	10038535	运模车后罩	BACK_COVER	1
42	20012671	开关盒盖板喷漆件	STOP_SWITCH_PLATE	1
43	20012670	开关盒喷漆件	STOP_SWITCH_BOX	1
44	10037725	启动开关(绿色)	STARTING_SWITCH(GREEN)	1
45	10039125	压框开关-黄色	PRESS_FOOT_FRAME_SWITCH(YELLO)	1
46	20013243	操作盒安装板喷漆件	INSTALL_PLATE	1
47	10031715	信号转接板	SIGNAL_SWITCH_BOARD	1
48	10024992	转接板支柱	SUPPORT_PILLAR	4
49	10009103	螺钉 M4 L=16	SCREW M4 L=16	4

2. 上轴、针杆部件

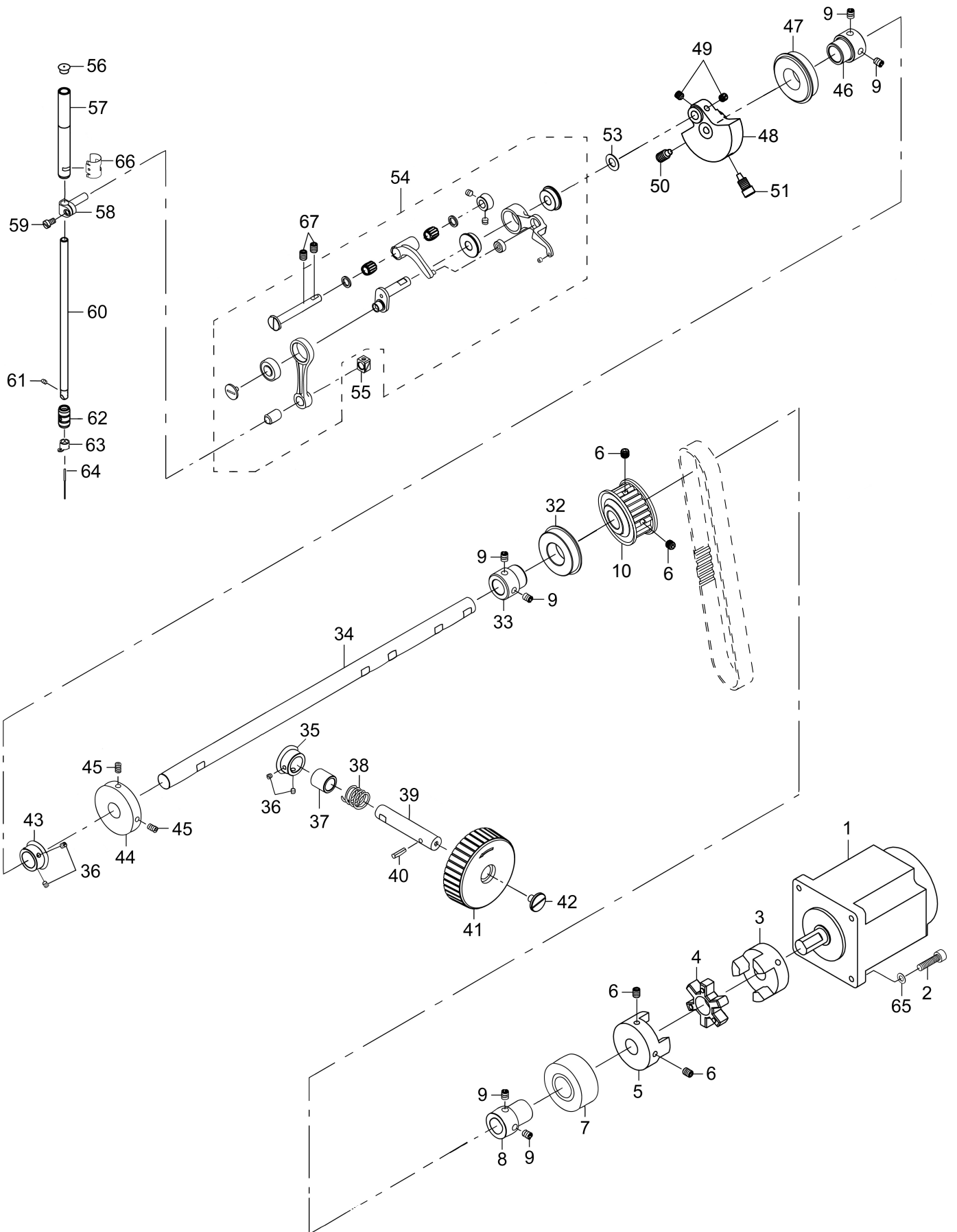

上轴、针杆部件

MAIN SHAFT & NEEDLE BAR COMPONENTS

序号 No.	件号 Part No.	名称	DESCRIPTION	数量 Qty
1	10031828	主轴电机	MAIN SHAFT SERVO MOTOR	1
2	10001943	螺钉 M5 L=20	SCREW M5 L=20	4
3	10012615	联轴器(1)	COUPLING (1)	1
4	10011227	联轴器橡胶块	COUPLING RUBBER	1
5	10012613	联轴器(2)	COUPLING (2)	1
6	10009187	螺钉 M6 L=8	SCREW M6 L=8	7
7	10025863	轴承 5204Z	BEARING 5204Z	1
8	10014264	轴承衬套	BEARING_BUSH	1
9	10010678	螺钉 SM15/64"×28 L=8	SCREW SM15/64"×28 L=8	6
10	10006241	上轴同步齿形带轮组件	UPPER SHAFT TENSION PULLEY ASM	1
32	10003547	轴承 6022VVNR	BEARING 6022VVNR	1
33	10014362	轴承衬套	BEARING_BUSH	1
34	10037696	上轴	MAIN SHAFT	1
35	10021312	齿轮 A	GEAR_A	1
36	10011226	螺钉 SM11/64"×40 L=2.8	SCREW SM11/64"×40 L=2.8	4
37	10027277	轴套	NEEDLE FEED SHAFT METAL	1
38	10011242	弹簧	SPRING	1
39	10027278	手轮轴	HANDWHEEL SHAFT	1
40	10006073	销	SPRING PIN	1
41	10011603	手轮	HANDWHEEL	1
42	10011225	螺钉 M6	HANDWHEEL SETSCREW M6	1
43	10027407	齿轮 B	GEAR_B	1
44	10009172	绕线主动轮	BOBBIN WINDER DRIVING WHEEL	1
45	10011223	螺钉 SM11/64"×40 L=11.5	SCREW SM11/64"×40 L=11.5	2
46	10014280	轴承衬套	BEARING_BUSH	1
47	10025882	轴承 6004NR-2RS_BOM	BEARING 6004NR-2RS	1
48	10012607	针杆曲柄	COUNTER WEIGHT	1
49	10005020	螺钉 SM1/4"×40 L=6	SCREW SM1/4"×40 L=6	2
50	10010082	螺钉 SM9/32"×28 L=16	SCREW SM9/32"×28 L=16	1
51	10010545	螺钉 SM9/32"×28 L=15	SCREW SM9/32"×28 L=15	1
53	10011622	垫圈 8×15×0.7	WASHER 8×15×0.7	1
54	10038440	挑线杆组件	THREAD_TAKE_UP_COMPL	1
55	10011194	针杆连接轴滑块	SLIDE BLOCK	1
56	10010587	橡胶塞	RUBBER PLUG	1
57	10027276	针杆上轴套	NEEDLE_BAR_METAL	1
58	10010590	针杆连接柱	NEEDLE BAR CONNECTING	1
59	10030286	螺钉 SM9/64"×40 L=6	SCREW SM9/64"×40 L=6	1
60	10000323	针杆	NEEDLE BAR	1
61	10010588	螺钉 SM1/8"×44 L=4.5	SCREW SM1/8"×44 L=4.5	1
62	10027275	针杆下轴套	NEEDLE_BAR_LOWER_METAL	1
63	10000237	针杆线钩	THREAD GUIDE	1
64	10038680	机针 DP×5 10#	NEEDLE DP×5 10#	1
65	10000260	垫圈 5.2×9.8×1	WASHER 5.2×9.8×1	4
66	10031678	挡油片	NEEDLE_BAR_METAL_GREASE_COVER	1
67	10009109	螺钉 M4 L=6	SCREW M4 L=6	2

3. 中压脚部件 (1)

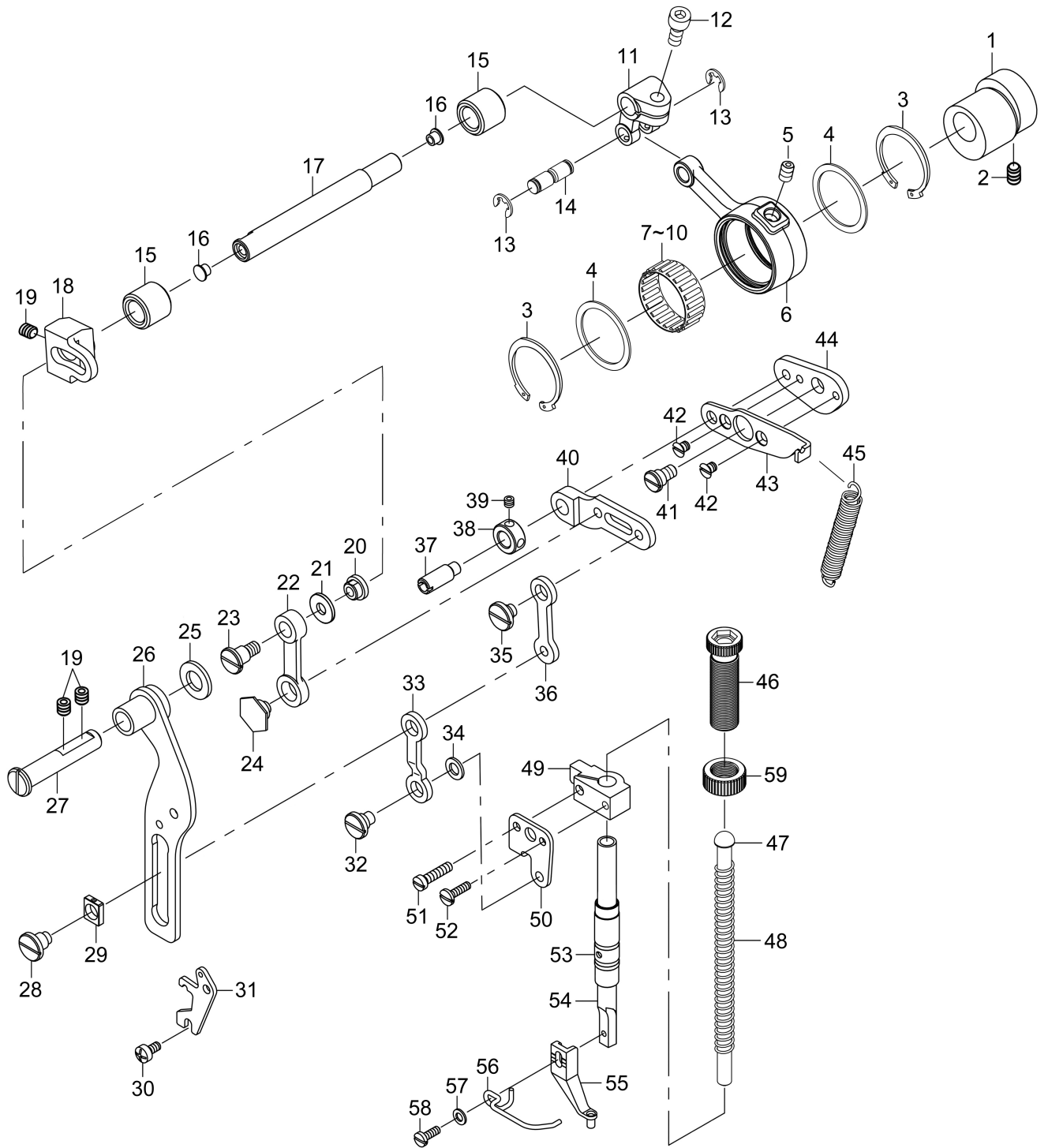

中压脚部件(1)

PRESSER MECHANISM & PRESSER VARIABLE COMPONENTS (1)

序号 No.	件号 Part No.	名称	DESCRIPTION	数量 Qty
1	10027282	偏心轮	ECCENTRIC CAM	1
2	10009187	螺钉 M6 L=8	SCREW M6 L=8	2
3	10030861	挡圈	RETAINING RING	2
4	10027336	垫圈 28.5×35×1	WASHER 28.5×35×1	2
5	10022863	螺钉 M6×0.75 L=6	SCREW M6×0.75 L=6	1
6	10027280	连杆	CRANK CONNECTING ROD	1
7	10029000	滚针轴承	NEEDLE BEARING	(1)
8	10029001	滚针轴承	NEEDLE BEARING	1
9	10029002	滚针轴承	NEEDLE BEARING	(1)
10	10029003	滚针轴承	NEEDLE BEARING	(1)
11	10000642	压脚同步曲柄	FORKED LINK	1
12	10009008	螺钉 M6 L=16	SCREW M6 L=16	1
13	10009654	开口挡圈 6	E-RING 6	2
14	10027283	销	CONNECTING SHAFT	1
15	10027284	轴套	BUSHING	2
16	10027286	橡胶塞	RUBBER PLUG	2
17	10027285	压脚行程调节曲柄轴	PRESSER WAVING SHAFT	1
18	10000479	压脚行程调节曲柄	ADJUSTING ARM	1
19	10011232	螺钉 M6 L=6	SCREW M6 L=6	3
20	10000632	螺母	ADJUSTING NUT	1
21	10000480	垫圈 6	WASHER 6	1
22	10027288	连杆	INTERMEDIATE PRESSURE LINK A	1
23	10027287	螺钉 SM15/64"×28	SCREW SM15/64"×28	1
24	10027289	螺钉 M6	SCREW M6	1
25	10027307	垫圈 10.4×19×2	WASHER 10.4×19×2	1
26	10027331	提升导轨组件	PRESSURE VARIABLE PLATE ASM	1
27	10027308	定位轴	LOCATING SHAFT	1
28	10027302	螺钉 M6	SCREW M6	1
29	10027301	压脚提升导轨滑块	SLIDE BLOCK	1
30	10009868	螺钉 M4 L=8	SCREW M4 L=8	2
31	10027293	复位簧拉板	SPRING LOCATING PLATE	1
32	10027303	螺钉 M6	SCREW M6	1
33	10027300	压脚提升导轨连杆	INTERMEDIATE PRESSURE LINK B	1
34	10012830	垫圈 6.2×10.3×1.2	WASHER 6.2×10.3×1.2	1
35	10027299	螺钉 M6	SCREW M6	1
36	10027298	压脚上下连杆	INTERMEDIATE PRESSURE LINK C	1
37	10000482	铰链螺钉	HINGE SCREW	1
38	10000483	挡圈	THRUST COLLAR	1
39	10013590	螺钉 SM11/64"×40 L=4	SCREW SM11/64"×40 L=4	2
40	10027290	压脚行程摆杆	INTERMEDIATE PRESSURE LINK D	1
41	10000481	螺钉 SM15/64"×28	SCREW SM15/64"×28	1
42	10000520	沉头螺钉 SM11/64"×40 L=4	SCREW SM11/64"×40 L=4	2
43	10027291	压脚调节复位板1	POSITIONING LINK 1	1
44	10027292	压脚调节复位板2	POSITIONING LINK 2	1
45	10027294	弹簧	SPRING	1
46	10034528	调压螺钉	PRESS ADJUSTING SCREW	1
47	10000636	压脚调压导杆	PRESSER GUIDE BAR	1
48	10000522	压脚调压簧	PRESS ADJUSTING SPRING	1
49	10027305	压杆导架	PRESSER BAR GUIDE BRACKET	1
50	10027304	提升板	LINK CONNECTING PLATE	1
51	10000380	螺钉 SM11/64"×40 L=18	SCREW SM11/64"×40 L=18	1
52	10000387	螺钉 SM9/64"×40 L=13.5	SCREW SM9/64"×40 L=13.5	1
53	10027306	压杆轴套	PRESSER BUSHING	1
54	10010646	压杆	PRESSER BAR	1
55	10000489	压脚	INTERMEDIATE PRESSER	1
56	10000487	护指架	FINGER GUARD	1
57	10011680	垫圈 4.6×9.7×0.8	WASHER 4.6×9.7×0.8	1
58	10010650	螺钉 SM9/64"×40 L=10.5	SCREW SM9/64"×40 L=10.5	1
59	10034529	调压螺母	PRESS ADJUSTING NUT	1

4. 中压脚部件 (2)

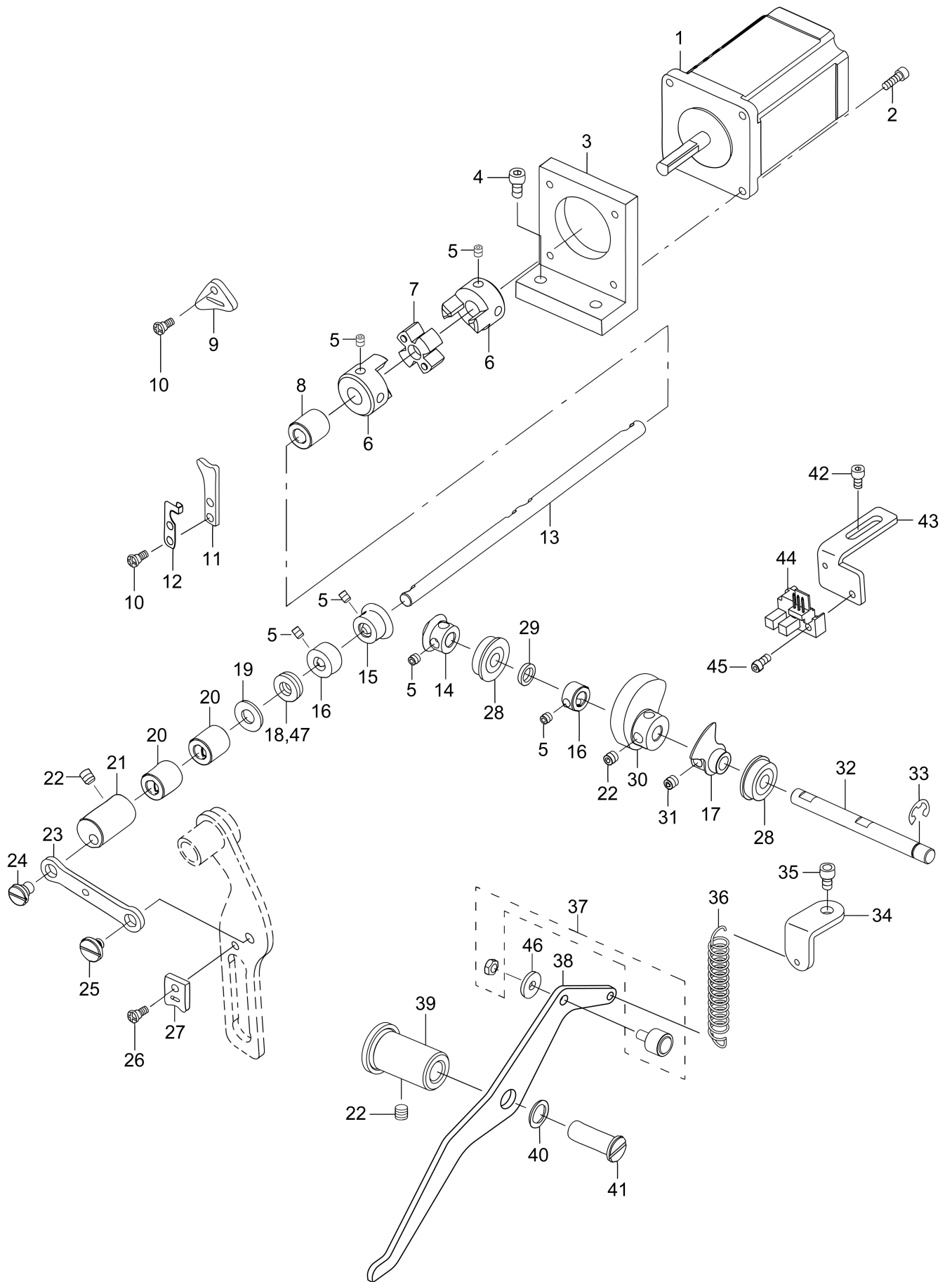

中压脚部件(2)

PRESSER MECHANISM & PRESSER VARIABLE COMPONENTS (2)

序号 No.	件号 Part No.	名称	DESCRIPTION	数量 Qty
1	10027402	步进电机	STEPPING MOTOR	1
2	10009103	螺钉 M4 L=16	SCREW M4 L=16	4
3	10027319	电机座	MOTOR BRACKET	1
4	10002028	螺钉 M6 L=20	SCREW M6 L=20	2
5	10012014	螺钉 M5 L=4	SCREW M5 L=5	12
6	10027317	联轴器	COUPLING	2
7	10027318	联轴器橡胶块	COUPLING RUBBER	1
8	10027314	轴套	BUSHING	1
9	10027295	油毡	OIL FELT PAD	1
10	10009868	螺钉 M4 L=8	SCREW M4 L=8	3
11	10027296	油毡	OIL FELT PAD	1
12	10027297	油毡架	OIL FELT PAD BRACKET	1
13	10027315	压脚提升连杆轴	PRESSER VARIABLE SHAFT	1
14	10027316	齿轮 A	GEAR A	1
15	10028805	齿轮 B	GEAR B	1
16	10027320	挡圈	THRUST COLLAR	2
17	10027334	电机传感片组件	SENSOR SLIT ASM	1
18	10007147	单向推力球轴承	BEARING	1
19	10000212	垫圈 8.5	WASHER 8.5	1
20	10027313	轴套	BUSHING	2
21	10027312	偏心轴	ECCENTRIC SHAFT	1
22	10011232	螺钉 M6 L=6	SCREW M6 L=6	5
23	10027310	压脚提升连杆	PRESSER VARIABLE LINK	1
24	10027311	螺钉 M6	SCREW M6	1
25	10030834	螺钉 M6	SCREW M6	1
26	10010193	螺钉 M4	SCREW M4	1
27	10027309	油毡	OIL FELT PAD	1
28	10003582	轴承 F608ZZ	BEARING F608ZZ	2
29	10026837	波形弹性垫圈 8	WAVED WASHER 8	1
30	10027321	压脚凸轮	LIFTING CAM	1
31	10011232	螺钉 M6 L=6	SCREW M6 L=6	2
32	10027322	压脚提升驱动轴	PRESSER LIFT SHAFT	1
33	10009654	E型挡圈 6	E-RING 6	1
34	10027323	抬压脚复位簧拉板	SPRING LOCATING PLATE	1
35	10000355	螺钉 M6 L=8	SCREW M6 L=8	1
36	10027326	弹簧	SPRING	1
37	10003657	凸轮从动轴承	CAM FOLLOWER	1
38	10027325	压脚驱动臂	LIFTING LINK	1
39	10027324	轴套	BUSHING	1
40	10000434	垫圈 11.2×16.3×1	WASHER 11.2×16.3×1	1
41	10027364	定位轴	LOCATING SHAFT	1
42	10001239	组合螺钉 M4 L=6	SCREW M4 L=6	2
43	10027335	中压脚传感器安装板	SENSOR INSTALLING BASE	1
44	10032404	传感器	SENSOR	1
45	10000984	组合螺钉 M3 L=8	SCREW M3 L=8	1
46	10027328	垫圈	WASHER	1
47	10007241	推力球轴承挡圈 8.3×16×1	WASHER 8.3×16×1	2

5. 辅助压脚、记号笔部件

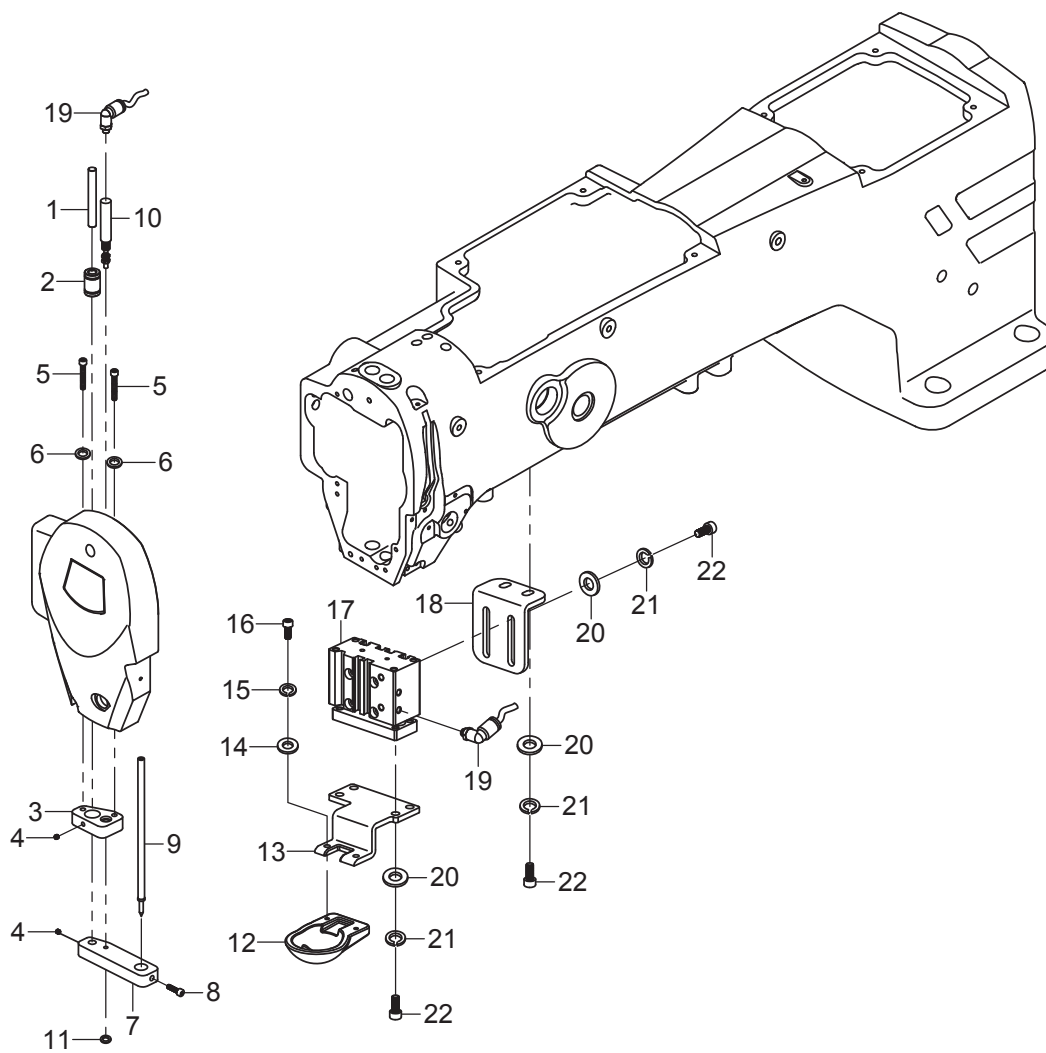

辅助压脚、记号笔部件 AUXILIARY PRESSER MECHANISM&MARKER PEN COMPONENTS

序号 No.	件号 Part No.	名称	DESCRIPTION	数量 Qty
1	10037645	辅助压脚导向销	AUXILIARY PRESSER FOOT GUIDE PIN	1
2	10037719	直线轴承 LM6UU	BEARING	1
3	10037714	记号笔固定块	MARKING PEN FIXATION	1
4	10002856	螺钉 M4 L=4	SCREW M4 L=4	2
5	10000863	螺钉 M4 L=12	SCREW M4 L=12	2
6	10001036	垫圈4.7	WASHER 4.7	2
7	10037713	记号笔连接块	MARKING PEN CONNECT	1
8	10037724	七角旋钮	SCREW	1
9		记号笔	MARKING PEN	
10	10037704	记号笔气缸	MARKING PEN CYLINDER	1
11	10000927	垫圈 3.2	WASHER 3.2	1
12	10039273	辅助压脚	AUXILIARY PRESSER FOOT	1
13	10039274	辅助压脚连接板	CONNECTION PLATE	1
14	10002954	垫圈 4	WASHER 4	2
15	10002991	弹簧垫圈 4	SPRING WASHER 4	2
16	10009103	螺钉 M4 L=16	SCREW M4 L=16	2
17	10039466	辅助压脚气缸	CYLINDER	1
18	10039275	辅助压脚气缸板	CYLINDER PLATE	1
19	10007681	气管接头	TIE-IN	3
20	10012318	垫圈 5	WASHER 5	10
21	10005537	弹簧垫圈 5	SPRING WASHER 5	10
22	10003164	螺钉 M5 L=16	SCREW M5 L=16	10

6. 松线部件

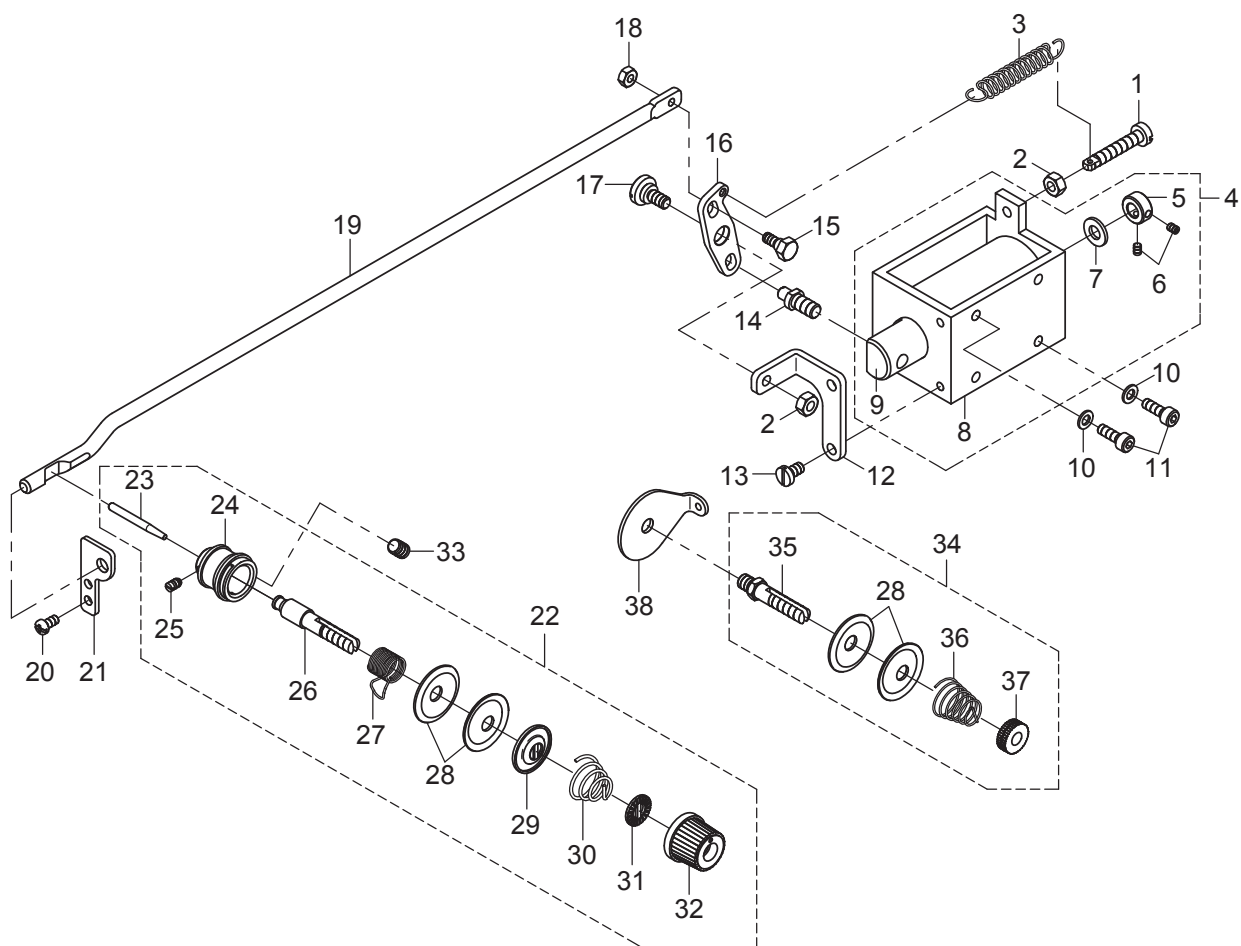

松线部件

TENSION RELEASE & THREAD TENSION COMPONENTS

序号 No.	件号 Part No.	名称	DESCRIPTION	数量 Qty
1	10014323	螺钉 M5 L=24	SCREW M5 L=24	1
2	10000353	螺母 M5	NUT M5	2
3	10014356	弹簧	SPRING	1
4	10038967	松线电磁铁组件	SOLENOID ASM	1
5	10008025	挡圈	THRUST COLLAR	(1)
6	10002853	螺钉 M3 L=4	SCREW M3 L=4	(2)
7	10008028	垫圈 12.3×18.5×3	WASHER 12.3×18.5×3	(1)
8	10027358	松线电磁铁线圈	SOLENOID COIL	(1)
9	10008029	松线电磁铁芯轴	SOLENOID MANDREL	(1)
10	10011680	垫圈 4.6×9.7×0.8	WASHER 4.6×9.7×0.8	2
11	10000863	螺钉 M4 L=12	SCREW M4 L=12	2
12	10014319	松线曲柄架	TENSION RELEASE CRANK FRAME	1
13	10010668	螺钉 SM11/64"×40 L=7.8	SCREW SM11/64"×40 L=7.8	2
14	10028973	螺钉 M6	SCREW M6	1
15	10027381	螺钉 M4	SCREW M4	1
16	10014316	松线曲柄	TENSION RELEASE CRANK	1
17	10014317	螺钉 M5	SCREW M5	1
18	10009471	螺母 M4	NUT M4	1
19	10029871	松线杆	TENSION RELEASE BAR	1
20	10011143	螺钉 SM9/64"×40 L=7	SCREW SM9/64"×40 L=7	2
21	10027356	松线杆定位板	TENSION RELEASE PLATE	1
22	10027360	夹线器组件	THREAD_TENSION_2_ASM	1
23	10027359	松线钉	TENSION RELEASE PIN	(1)
24	10004631	夹线器座	THREAD_TENSION_POST_BASE	(1)
25	10004632	螺钉 SM9/64"×40 L=6	SCREW SM9/64"×40 L=6	(1)
26	10002407	夹线器总螺钉	SCREW	(1)
27	10004730	弹簧	SPRING	(1)
28	10004393	夹线板	THREAD_TENSION_DISK	(2)
29	10004625	松线板	THREAD_TENSION_DISK_PRESSER	(1)
30	10004626	弹簧	SPRING	(1)
31	10004633	夹线制动板	DISK_STOPPER	(1)
32	10004523	夹线螺母组件	THREAD TENSION NUT	(1)
33	10010678	螺钉 SM15/64"×28 L=8	SCREW SM15/64"×28 L=8	1
34	10011493	夹线组件	THREAD_TENSION_1_ASM	1
35	10004666	螺钉 SM15/64"×28	SCREW SM15/64"×28	(1)
36	10004669	弹簧	SPRING	(1)
37	10004664	螺母 SM1/4"×40	SCREW SM1/4"×40	(1)
38	10000541	夹线器过线器	THREAD GUIDE	1

7. 拨线部件

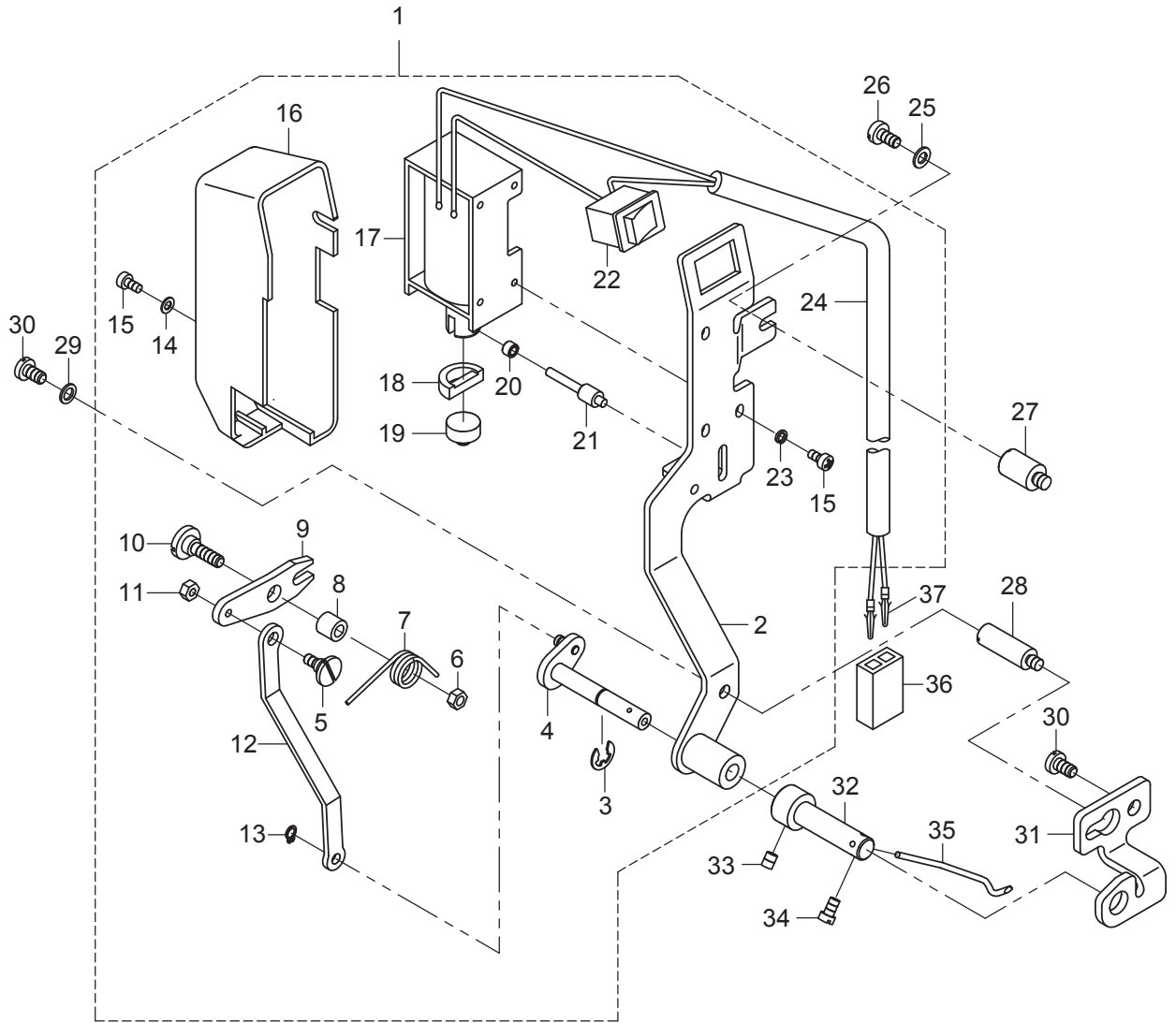

拨线部件

WIPER MECHANISM COMPONENTS

序号 No.	件号 Part No.	名称	DESCRIPTION	数量 Qty
1	10027354	拨线电磁铁组件	WIPER ASM	1
2	10027353	拨线电磁铁支架组件	WIPER_BASE_ASM	(1)
3	10010649	挡圈	E-RING	(1)
4	10005730	拨线驱动轴部件	WIPER_DRIVING_SHAFT_ASM	(1)
5	10005738	螺钉 SM9/64"×40	SCREW SM9/64"x40	(1)
6	10005735	螺母 SM11/64"×40	NUT SM11/64"x40	(1)
7	10005770	弹簧	SPRING	(1)
8	10005767	轴套	WIPER_HINGE_SCREW_COLLAR	(1)
9	10005728	拨线传动板	WIPER_LINK_B	(1)
10	10005726	螺钉 SM11/64"×40	SCREW SM11/64"x40	(1)
11	10005766	螺母 SM9/64"×40	NUT SM9/64"x40	(1)
12	10027351	拨线拉杆	WIPER_LINK_A	(1)
13	10024749	挡圈	RING	(1)
14	10003017	垫圈 3	WASHER 3	(1)
15	10003036	螺钉 M3 L=6	SCREW M3 L=6	(4)
16	10005724	拨线器罩	WIPER COVER	(1)
17	10005736	拨线电磁铁	WIPER_SOLENOID	(1)
18	10005739	铁芯橡皮垫	WIPER RUBBER A	(1)
19	10012488	铁芯复位垫	WIPER RUBBER B	(1)
20	10005769	传动销滚柱	WIPER LINK COLLAR	(1)
21	10005719	销	WIPER_SOLENOID_SHAFT	(1)
22	10005731	拨线器开关	SWITCH	(1)
23	10003082	弹簧垫圈 3	WASHER 3	(3)
24	10005732	拨线器电线	ELECTRIC WIRE	(1)
25	10011680	垫圈 4.6×9.7×0.8	WASHER 4.6x9.7x0.8	1
26	10009868	螺钉 M4 L=8	SCREW M4 L=8	1
27	10027350	支架螺钉	SCREW	1
28	10000017	滑臂安装板螺柱	SCREW	1
29	10001036	垫圈 4.7×7.4×0.8	WASHER 4.7x7.4x0.8	1
30	10010668	螺钉 SM11/64"×40 L=7.8	SCREW SM11/64"x40 L=7.8	3
31	10000013	滑臂安装板	WIPER_SHAFT_SUPPORT_BRACKET	1
32	10000014	挑线杆滑臂	WIPER_SHAFT_CAP	1
33	10000563	螺钉 M4 L=5	SCREW M4 L=5	1
34	10010071	螺钉 SM9/64"×40 L=6	SCREW SM9/64"x40 L=6	1
35	10000015	拨线杆	WIPER	1
36	10002454	插接件公端2芯	2-POLE NYLON PLUG	1
37	10002459	芯针孔端	PIN CONTACT	2

8. 下轴剪线部件

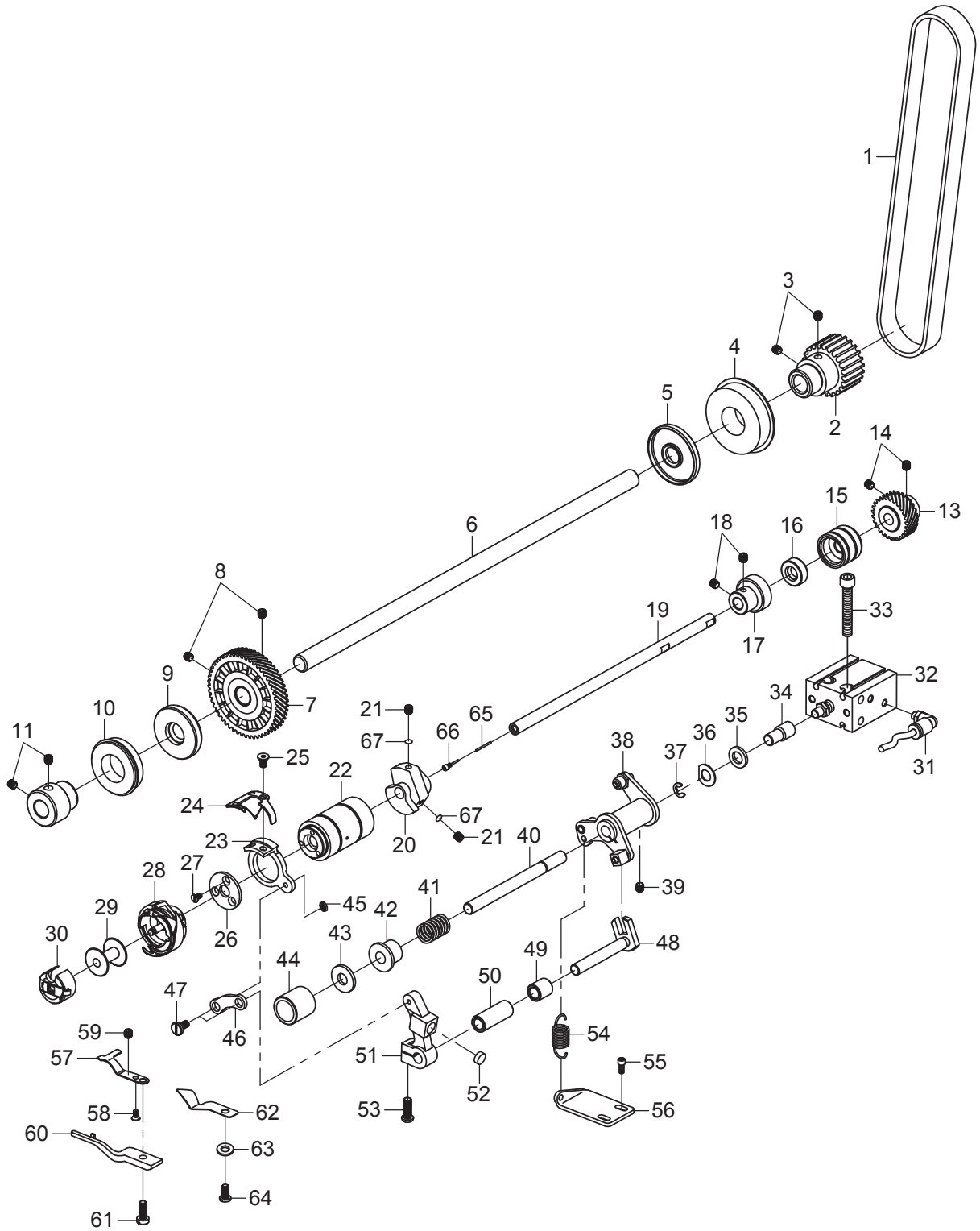

下轴剪线部件

LOWER SHAFT TRIM THREAD COMPONENTS

序号 No.	件号 Part No.	名称	DESCRIPTION	数量 Qty
1	10037786	上轴同步带	TIMING BELT	1
	10037787	上轴同步带	TIMING BELT	
	10037788	上轴同步带	TIMING BELT	
2	10012535	抬牙轴同步齿形带轮	LOWER SPROCKET	1
3	10025881	轴承 6204NR-2RS	BEARING 6204NR-2RS	1
4	10009187	螺钉 M6 L=8	SCREW M6 L=8	2
5	10012538	油封	OIL SEAL	1
6	10037698	带轮轴	SHAFT	1
7	10012462	齿轮	DRIVE GEAR	1
8	10008862	螺钉 SM1/4"×40	SCREW SM1/4"x40	2
9	10012533	油封	OIL SEAL	1
10	10037722	轴承 6904ZZNR	BEARING 6904ZZNR	1
11	10037694	轴承衬套	BEARING SUPPORT	1
12	10010678	螺钉 SM15/64"×28	SCREW SM15/64"x28	2
13	10012554	齿轮	DRIVE GEAR	1
14	10008862	螺钉 SM1/4"×40	SCREW SM1/4"x40	2
15	10012678	轴套	HOOK SHAFT REAR METAL	1
16	10012423	油封	OIL SEAL	1
17	20000175	轴承组件	BEARING	1
18	10013590	螺钉 SM11/64"×40	SCREW SM11/64"x40	2
19	10037697	下轴	HOOK SHAFT	1
20	10010736	剪线凸轮	THREAD TRIMMER CAM	1
21	10013465	螺钉 SM1/4"×40	SCREW SM1/4"x40	2
22	20002975	轴套组件	HOOK SHAFT METAL COMPL	1
23	10013045	动刀架	ROUND KNIFE BRACKET	1
24	10030280	动刀	ROUND KNIFE	1
25	10011588	螺钉 SM11/64"×40	SCREW SM11/64"x40	2
26	10013026	刀架压板	KNIFE HOLDER	1
27	10009626	螺钉 M3 L=4.35	SCREW M3 L=4.35	3
28	10038530	旋梭 HSH-7.94BOTR_MD	SHUTTLE	1
29	10025484	梭芯	BOBBIN	1
30	10006924	梭壳 BC-DB1-NBL6	BOBBIN CASE	1
31	10007681	气管接头	HOSE ELBOW	2
32	10037705	剪线气缸	AIR CYLINDER	1
33	10009520	螺钉 M5 L=25	SCREW M5 L=25	2
34	10037640	剪线气缸接头	CYLINDER KNUCKLE	1
35	10011650	垫圈 8.2×15×2	WASHER 8.2x15x28.2	1
36	10014460	垫圈 8.2	WASHER 8.2	1
37	10009654	挡圈 6	E-RING 6	1
38	10039207	切线凸轮曲柄组件	TRIMMING CAM CRANK ASM	1
39	10008862	螺钉 SM1/4"×40	SCREW SM1/4"x40	1
40	10011697	切刀驱动轴	TRIMMING SHAFT	1
41	10008812	弹簧	SPRING	1
42	10014196	扭簧端盖	SPRING COVER	1
43	10013008	垫圈 8.2	WASHER 8.2	1
44	10014462	轴套	BUSHING	1
45	10011578	螺母 SM11/64"×40	SCREW SM11/64"x40	1
46	10013044	刀轴连杆	KNIFE SHAFT CONNECTING BAR	1
47	10011514	螺母 SM11/64"×40	SCREW SM11/64"x40	2
48	10013007	切线驱动曲柄轴	TRIMMING CRANK SHAFT	1
49	10013027	轴套	BUSHING	1
50	10013024	轴套	BUSHING	1
51	10013013	切线驱动曲柄	TRIMMING CRANK	1
52	10013010	切线驱动曲柄止动块	Crank Block	1
53	10009818	螺钉 SM3/16"×32	SCREW SM3/16"x32	1
54	10028226	弹簧	SPRING	1
55	10000863	螺钉 M4 L=12	SCREW M4 L=12	2
56	10038523	剪线拉簧板	FIXED PLATE	1
57	10011421	定刀	FIXED KNIFE	1
58	10011422	螺钉 SM9/64"×40	SCREW SM9/64"x40	1
59	10024496	螺钉 SM1/8"×40	SCREW SM1/8"x40	1
60	10031259	旋梭定位钩	BOBBIN CASE HOLDER	1
	10031260	旋梭定位钩	BOBBIN CASE HOLDER	
	10031261	旋梭定位钩	BOBBIN CASE HOLDER	
61	10010066	螺钉 SM11/64"×40	SCREW SM11/64"x40	1
62	10011584	分线器	DISPART THREAD SHUTTLE	1
63	10013154	垫圈 9×4.5×0.8	WASHER 9x4.5x0.8	1
64	10014474	螺钉 SM11/64"×40	SCREW SM11/64"x40	1
65	10010063	油芯	OIL WICK	1
66	10010064	螺钉 SM3/16"×32	SCREW SM3/16"x32	1
67	10023739	剪线凸轮垫	THREAD TRIMMER CAM WASHER	2

9. 润滑部件

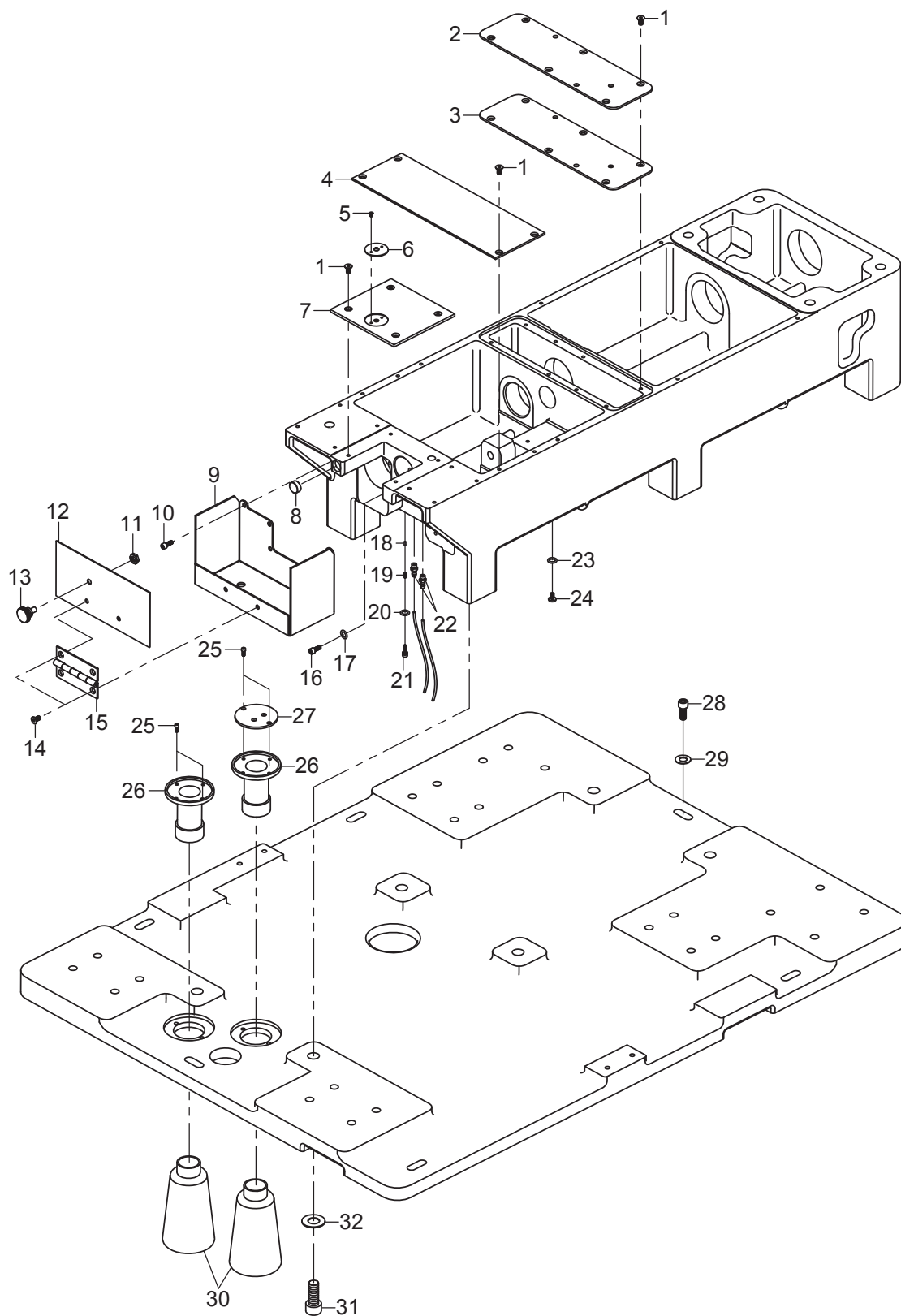

润滑部件

LUBRICATION COMPONENTS

序号 No.	件号 Part No.	名称	DESCRIPTION	数量 Qty
1	10037841	平机螺栓 M4 L=8	SCREW M4 L=8	50
2	10037679	齿轮箱盖板	TANK COVER PLATE	1
3	10038525	齿轮箱盖板垫	COVER MAT	1
4	10037668	剪线上盖板	COVER PLATE	1
5	10011509	螺钉 SM3/32"×56 L=1.8	SCREW SM3/32"×56 L=1.8	2
6	10038528	运模车小针板	SMALL NEEDLE PLATE	1
7	10037665	方形针板	SQUARE NEEDLE PLATE	1
8	10001096	磁铁	MEGNET	1
9	10037687	接油盒	OIL BOX	1
10	10009868	螺钉 M4 L=8	SCREW M4 L=8	5
11	10009467	螺母 M5	NUT M5	1
12	10037688	油盖板	OIL COVER PLATE	1
13	10037648	滚花高头螺钉	SCREW	1
14	10014441	螺钉 M4 L=6	SCREW M4 L=6	4
15	10030965	蝶形铰链	HINGE	1
16	10012667	螺钉 SM11/64"×40	SCREW SM11/64"×40	1
17	10012606	O形圈 4.5×2	O TYPE RING 4.5×2	1
18	10012609	柱塞	PLUNGER	1
19	10014386	柱塞簧	PLUNGER SPRING	1
20	10014461	O形圈 6.5×2	O TYPE RING 6.5×2	1
21	10013025	螺钉 SM1/16"×24	SCREW SM1/16"×24	1
22	10008779	油管接头	CONNECTOR	2
23	10014461	O形圈 6.5×2	O TYPE RING 6.5×2	1
24	10008783	螺钉 SM5/16"×24	SCREW SM5/16"×24	1
25	10005041	内六角圆头螺栓 M4 L=10	BOLT M4 L=10	4
26	10011683	油杯座	SEAT	2
27	10037680	油盖板	OIL COVER PLATE	1
28	10001862	螺钉 M8 L=30	SCREW M8 L=30	6
29	10003020	垫圈 8 GB/T 97.1-2002	WASHER 8 GB/T 97.1-2002	6
30	10011681	油杯	OIL CUP	2
31	10007432	螺钉 M10 L=30	SCREW M8 L=30	6
32	10001937	垫片 10.4×20×2	WASHER 10.4×20×2	6

10. X-Y送料部件 (1)

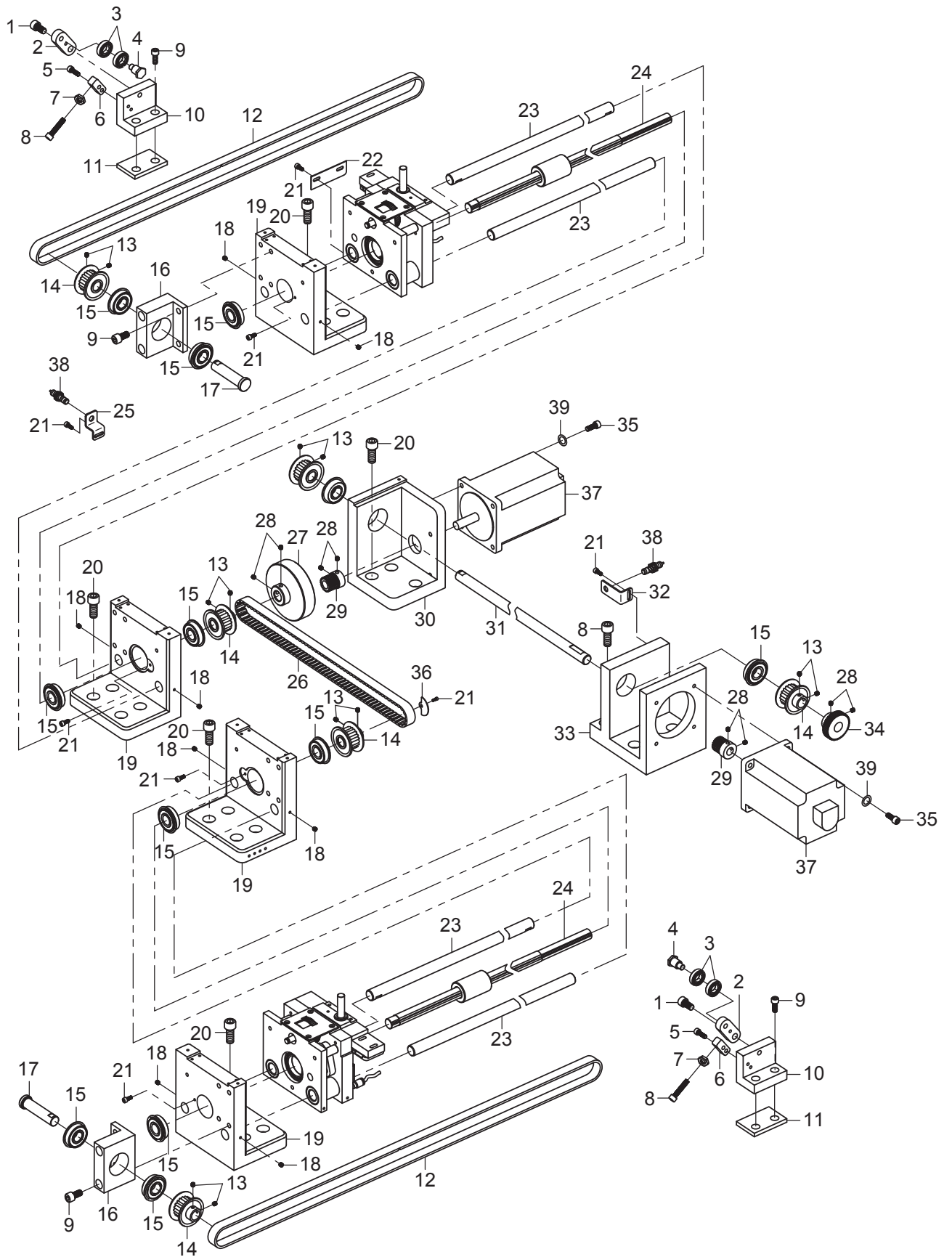

X-Y送料部件(1)

FEEDING COMPONENTS(1)

序号 No.	件号 Part No.	名称	DESCRIPTION	数量 Qty
1	10003142	螺钉 M8 L=25	SCREW M8 L=25	2
2	10037638	涨紧板	PLATE	2
3	10012777	轴承 6901ZZ	BEARING 6901ZZ	4
4	10037642	销	PIN	2
5	10009520	螺钉 M5 L=25	SCREW M5 L=25	4
6	10037637	涨紧座 2	SEAT 2	2
7	10003032	螺母 M6	NUT M6	2
8	10003158	螺钉 M6 L=25	SCREW M6 L=25	2
9	10002028	螺钉 M6 L=20	SCREW M6 L=20	4
10	10037663	涨紧座	SEAT	2
11	10038971	涨紧座垫板	SEAT PLATE	2
12	10038526	开口橡胶同步带A	TIMING BELT A	2
13	10004949	螺钉 M5 L=8	SCREW M5 L=8	12
14	10037650	X向同步带轮	X-DRIVEN SPROCKET	6
15	10009787	轴承 6202ZZNR	BEARING 6202ZZNR	12
16	10037662	Y向带轮座	Y-DRIVEN BRACKET	2
17	10037643	带轮定位轴	PULLEY FIX SHAFT	2
18	10004949	螺钉 M5 L=8	SCREW M5 L=8	8
19	10037661	送料支撑座	BRACKETS	2
20	10007432	螺钉 M10 L=30	SCREW M10 L=30	23
21	10001239	螺钉组件	SCREW	11
22	10037682	Y向传感器检测板	Y-SENSOR SLIT	1
23	10037700	X向导向轴	X GUIDE SHAFT	4
24	10037717	花键轴	DRIVE SPLINE SHAFT	2
25	10037686	Y向传感器座	Y-SENSOR INSTALLING PLATE	1
26	10037655	X向同步带	X-TIMING BELT	1
27	10037635	X向从动齿轮	X-DRIVEN GEAR	1
28	10011232	螺钉 M6 L=6	SCREW M6 L=6	6
29	10037636	主动齿轮	DRIVE_GEAR	2
30	10037659	X向电机座	X MOTOR SEAT	1
31	10037699	Y向导向轴	Y GUIDE SHAFT	1
32	10037685	X向传感器座	X-SENSOR INSTALLING PLATE	1
33	10037660	Y向电机座	Y MOTOR SEAT	1
34	10037634	Y向从动齿轮	Y-DRIVEN GEAR	1
35	10002028	螺钉 M6 L=20	SCREW M6 L=20	8
36	10000713	Y轴电机传感片	Y-SENSOR SLIT	1
37	10039031	X/Y轴步进电机	X/Y STEP MOTER	1
38	10039036	传感器	SENSOR	2
39	10000109	垫片 6.6×10.7×1	WASHER 6.6×10.7×1	8

11. X-Y送料部件 (2)

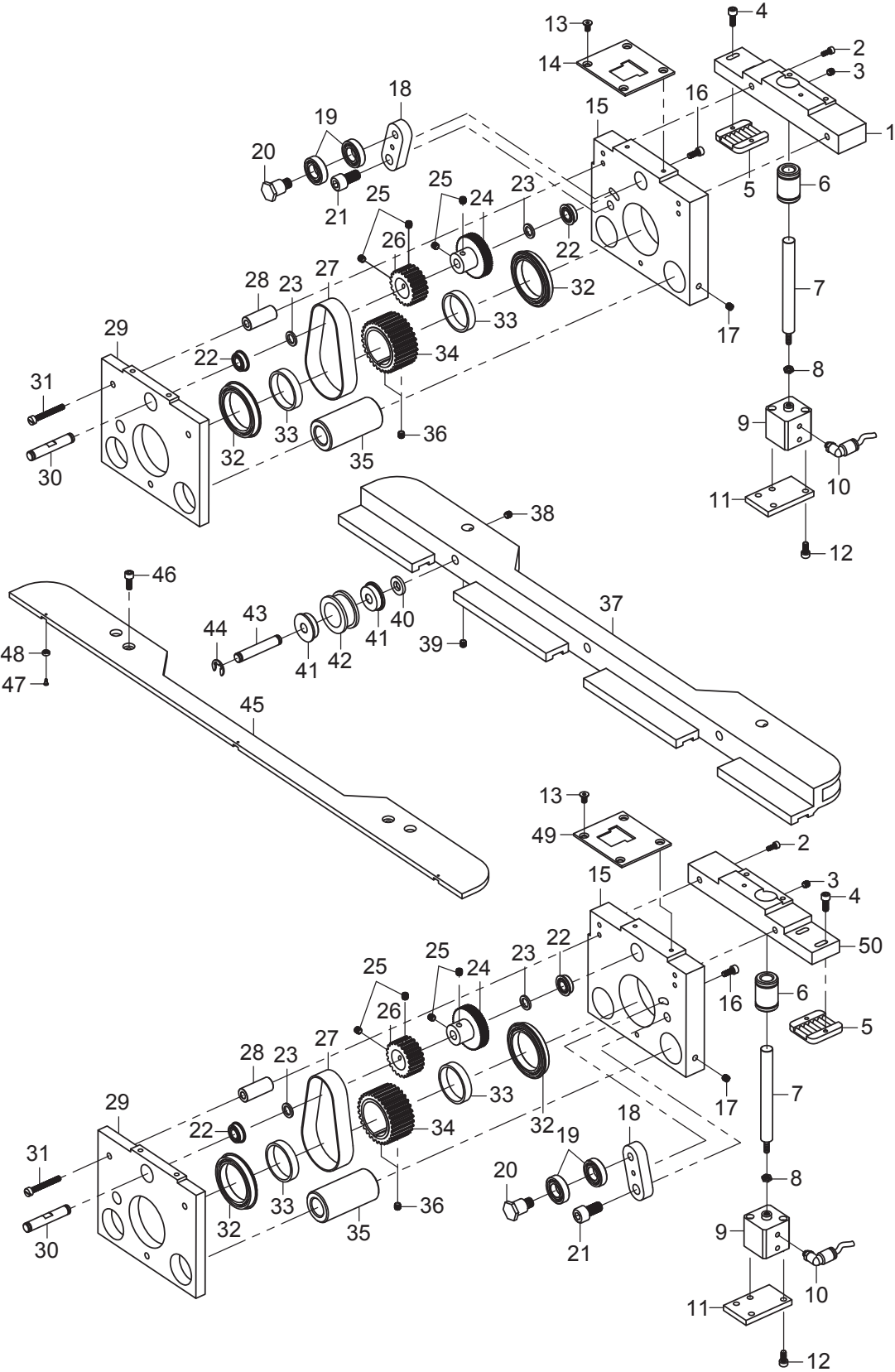

X-Y送料部件(2)

FEEDING COMPONENTS(2)

序号 No.	件号 Part No.	名称	DESCRIPTION	数量 Qty
1	10037711	直线轴承座左	BEARING SEAT LEFT	1
2	10002233	螺钉 M5 L=25	SCREW M5 L=25	4
3	10012162	螺钉 M5 L=5	SCREW M5 L=5	2
4	10037649	同步带压板	TIMING BELT PLATE	2
5	10000381	螺钉 M4 L=20	SCREW M4 L=20	4
6	10003647	轴承 SDM10UU	BEARING SDM10UU	2
7	10037701	导向杆	GUIDE BAR	2
8	10005297	螺母 M4	NUT M4	2
9	10037702	压料气缸	CYLINDER	2
10	10007681	气管接头	CONTACT	4
11	10037690	气缸支座	BRACKETS	2
12	10000863	螺钉 M4 L=12	SCREW M4 L=12	8
13	10037841	平机螺栓 M4 L=8	SCREW M4 L=8	8
14	10037666	带轮盖板左	COVER PLATE LEFT	1
15	10037706	基座A	BRACKETS A	2
16	10009520	螺钉 M5 L=25	SCREW M5 L=25	2
17	10002856	螺钉 M4 L=4	SCREW M4 L=4	4
18	10037638	涨紧板	PLATE	2
19	10012777	轴承 6901ZZ	BEARING 6901ZZ	4
20	10037642	销	PIN	2
21	10003142	螺钉 M8 L=25	SCREW M8 L=25	2
22	10026126	轴承 F688ZZ	BEARING F688ZZ	4
23	10037678	送料同步轮垫圈 1.5	GASKET 1.5	4
24	10037653	X向同步带轮C	X-DRIVEN SPROCKET C	2
25	10012014	螺钉 M5 L=4	SCREW M5 L=4	8
26	10037652	X向同步带轮B	X-DRIVEN SPROCKET B	2
27	10037656	Y向同步带	Y-TIMING BELT	2
28	10037639	连接柱	JOINT PIN	6
29	10037707	基座B	BRACKETS B	2
30	10027380	X向从动轴	X-DRIVEN	2
31	10008260	螺钉 M5 L=50	SCREW M5 L=50	6
32	10037718	轴承 6807ZZNR	BEARING 6807ZZNR	4
33	10037695	衬套	BUSHING	4
34	10037651	X向同步带轮A	X-DRIVEN SPROCKET A	2
35	10037720	直线轴承 LM16LUU	BEARING LM16LUU	4
36	10002856	螺钉 M4 L=4	SCREW M4 L=4	4
37	10037708	送料座	BRACKETS	1
38	10009187	螺钉 M6 L=8	SCREW M6 L=8	2
39	10002856	螺钉 M4 L=4	SCREW M4 L=4	3
40	10010804	垫圈 8.2×16×2.5	GASKET 8.2x16x2.5	3
41	10003582	轴承 F608ZZ	BEARING F608ZZ	6
42	10037712	压料轮	PRESS PULLEY	3
43	10027380	X向从动轴	X-DIVEN SHAFT	3
44	10009654	挡圈 6	WASHER 6	3
45	10037709	压紧座	BRACKETS	1
46	10003049	螺钉 M4 L=12	SCREW M4 L=12	2
47	10037647	铆钉销	PIN	3
48	10037723	微型球轴承 682ZZ	BEARING 682ZZ	3
49	10037667	带轮盖板右	COVER PLATE RIGHT	1
50	10037710	直线轴承座右	BEARING SEAT RIGHT	1

12. 气动部件

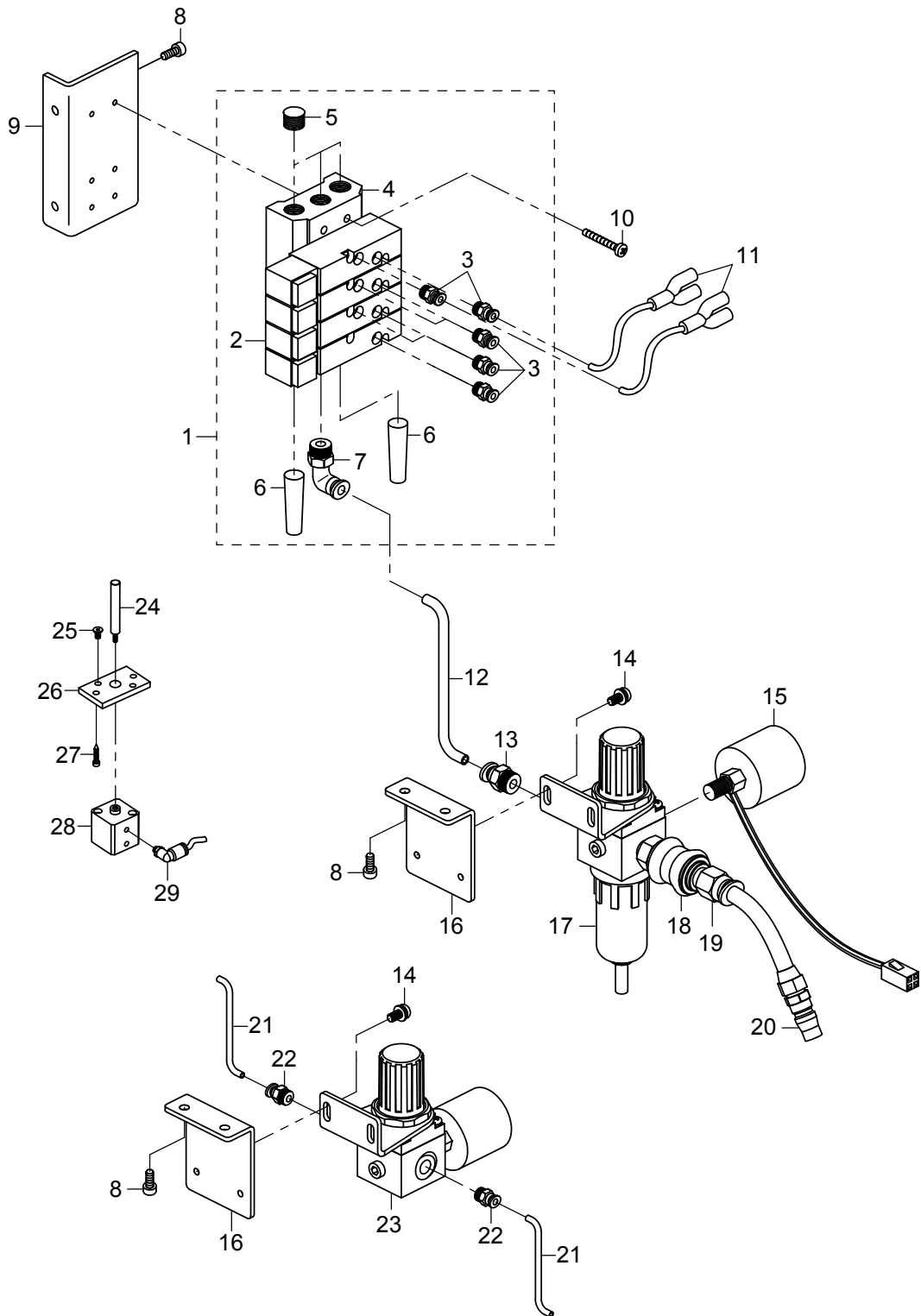

气动部件

PNEUMATIC COMPONENTS

序号 No.	件号 Part No.	名称	DESCRIPTION	数量 Qty
1	10037929	四电磁阀组件	4 PORT SOLENOID VALVE GROUP	1
2	10007696	电磁阀	5 PORT SOLENOID VALVE	4
3	10023253	快速接头 $\phi 4 \times R1/8$	HALF UNION $\phi 4 \times R1/8$	7
4	10035678	电磁阀底座	SOLENOID VALVE BASE	1
5	10031291	堵头	PLUG	3
6	10031292	A型清音器	MUFFLER	2
7	10003724	快插式直角终端接口	HALF UNION	6
8	10005322	螺钉 M5 L=10	SCREW M5 L=10	8
9	10031324	阀板固定板	BASE INSTALLING PLATE	1
10	10002180	螺钉 M4 L=30	SCREW M4 L=30	4
11	10007701	快换接头	Y-QUICK COUPLING	4
12	10008150	气管	TUBE	
13	10003733	快速接头 $\phi 6 \times R1/4$	HALF UNION $\phi 6 \times R1/4$	1
14	10003883	面板螺钉	SCREW	6
15	10007620	带压力开关的压力表	AIR PRESSURE SWITCH	1
16	10001107	固定板	BASE INSTALLING PLATE	3
17	10007604	过滤减压阀	FILTER REGULATOR	1
18	10007534	手滑阀	HAND SLIDE VALVE	1
19	10003458	阀进气直通接头 $\phi 10$	HALF UNION $\phi 10 \times R1/4$	1
20	10024399	接头	PLUG $\phi 10 \times R1/4$	1
21	10008119	气管	TUBE	
22	10023253	快速接头 $\phi 4 \times R1/8$	HALF UNION $\phi 4 \times R1/8$	4
23	10002884	减压阀	REDUCING VALVE	2
24	10037646	限位销	LIMIT PIN	1
25	10028144	螺钉 M4 L=10	SCREW M4 L=10	2
26	10037689	气缸安装板	CYLINDER COVER	1
27	10008323	自攻螺钉	SCREW	2
28	10037702	压料气缸	CYLINDER	1
29	10007681	气管接头	CONNECT	2

13. 大縫台部件

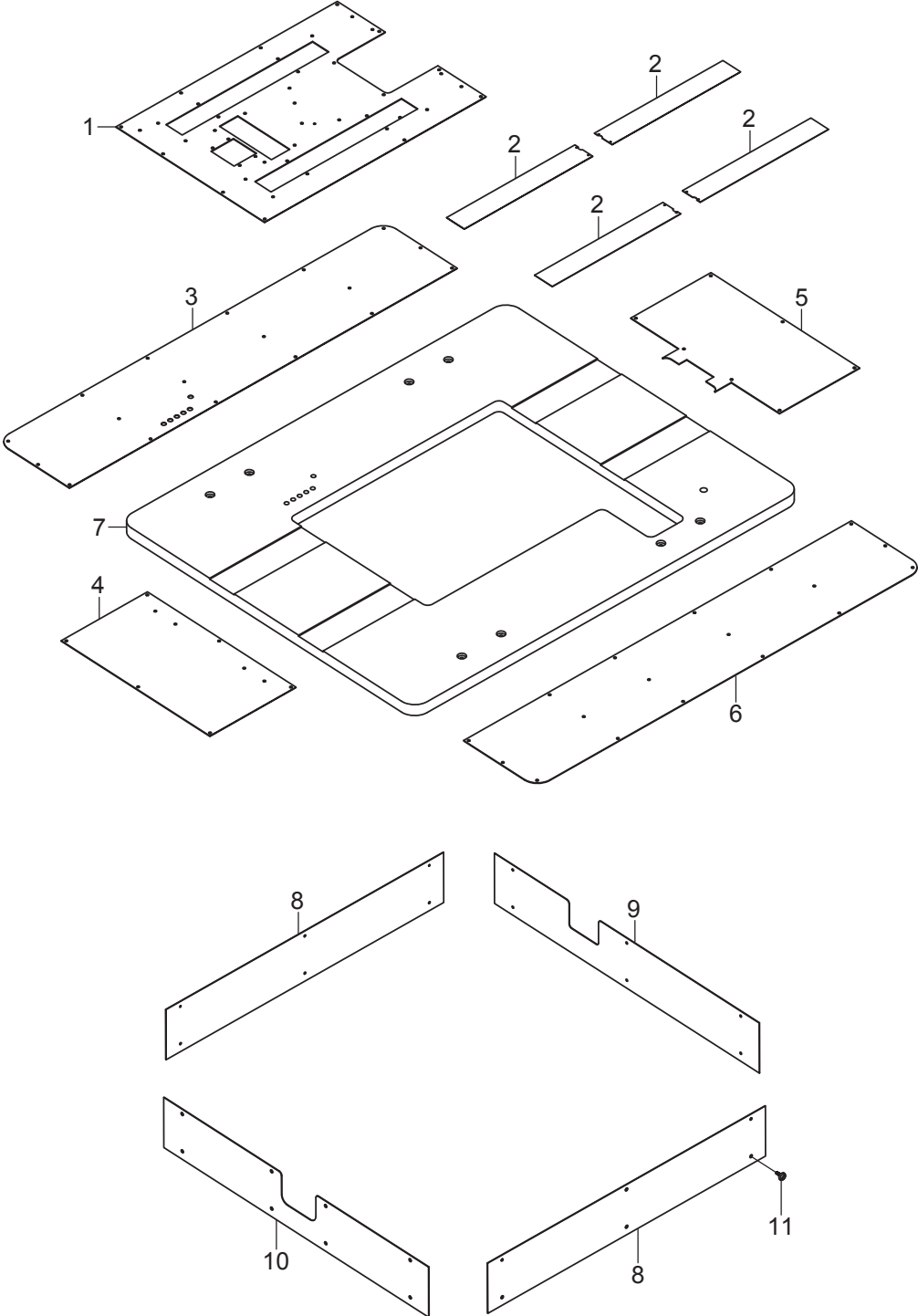

大缝台部件

BIG SEWING BED COMPONENTS

序号 No.	件号 Part No.	名称	DESCRIPTION	数量 Qty
1	10037670	底板上盖板	COVER PLATE	1
2	10037669	滑移板	SLIDING PLATE	4
3	10037671	台板贴A	TABBLE LABEL A	1
4	10037672	台板贴B	TABBLE LABEL B	1
5	10037673	台板贴C	TABBLE LABEL C	1
6	10037674	台板贴D	TABBLE LABEL D	1
7	30007690	运模机台板	TABBLE	1
8	10037677	侧挡板	SIDE BAFFLE	2
9	10037676	后挡板	BACK BAFFLE	1
10	10037675	前挡板	FRONT BAFFLE	1
11	10011260	螺钉 M5 L=12	SCREW M5 L=12	26

14. 机架部件

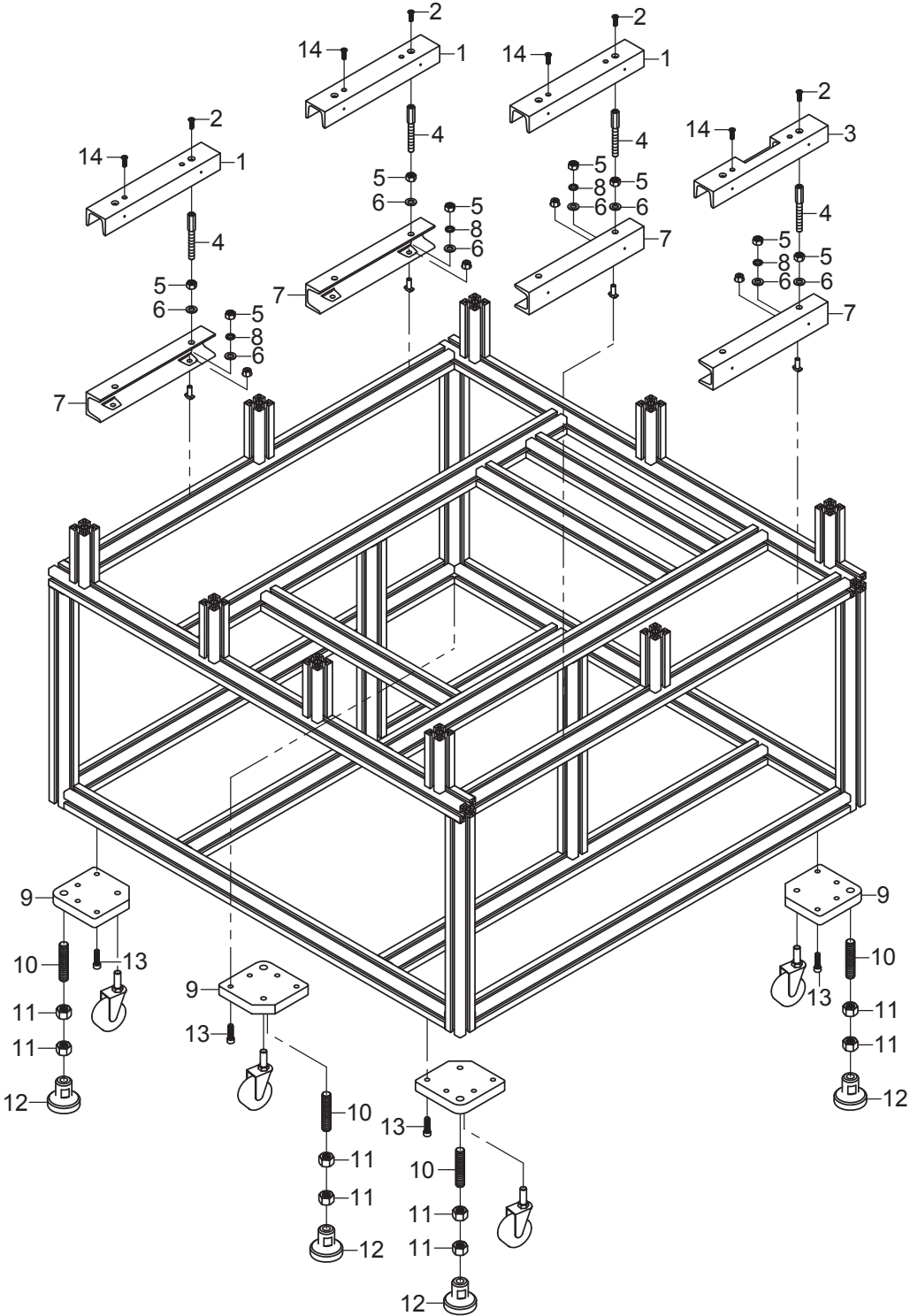

机架部件

MACHINE STAND COMPONENTS

序号 No.	件号 Part No.	名称	DESCRIPTION	数量 Qty
1	10037152	槽钢组件	CHANNEL STEEL COMPONENTS	3
2	10002852	螺钉 M6 L=16	SCREW M6 L=16	8
3	10038968	槽钢5-280	CHANNEL STEEL 5-280	1
4	10037149	支撑杆	SUPPORT BAR	8
5	10012605	M10螺母	NUT M=10	16
6	10003087	10垫圈	WASHER 10	8
7	10037140	槽钢5-300-2	CHANNEL STEEL 5-300-2	4
8	10003000	10垫圈	WASHER 10	8
9	10037155	脚座垫板	STAND PLATE	4
10	10037150	螺杆	SCREW	4
11	10002985	螺母 M16	NUT M=16	16
12	10037156	脚座	FOOTSTAND	4
13	10001862	螺钉 M8 L=30	SCREW M8 L=30	16
14	10007595	螺钉 M6 L=40	SCREW M6 L=40	8

15. 附件部件

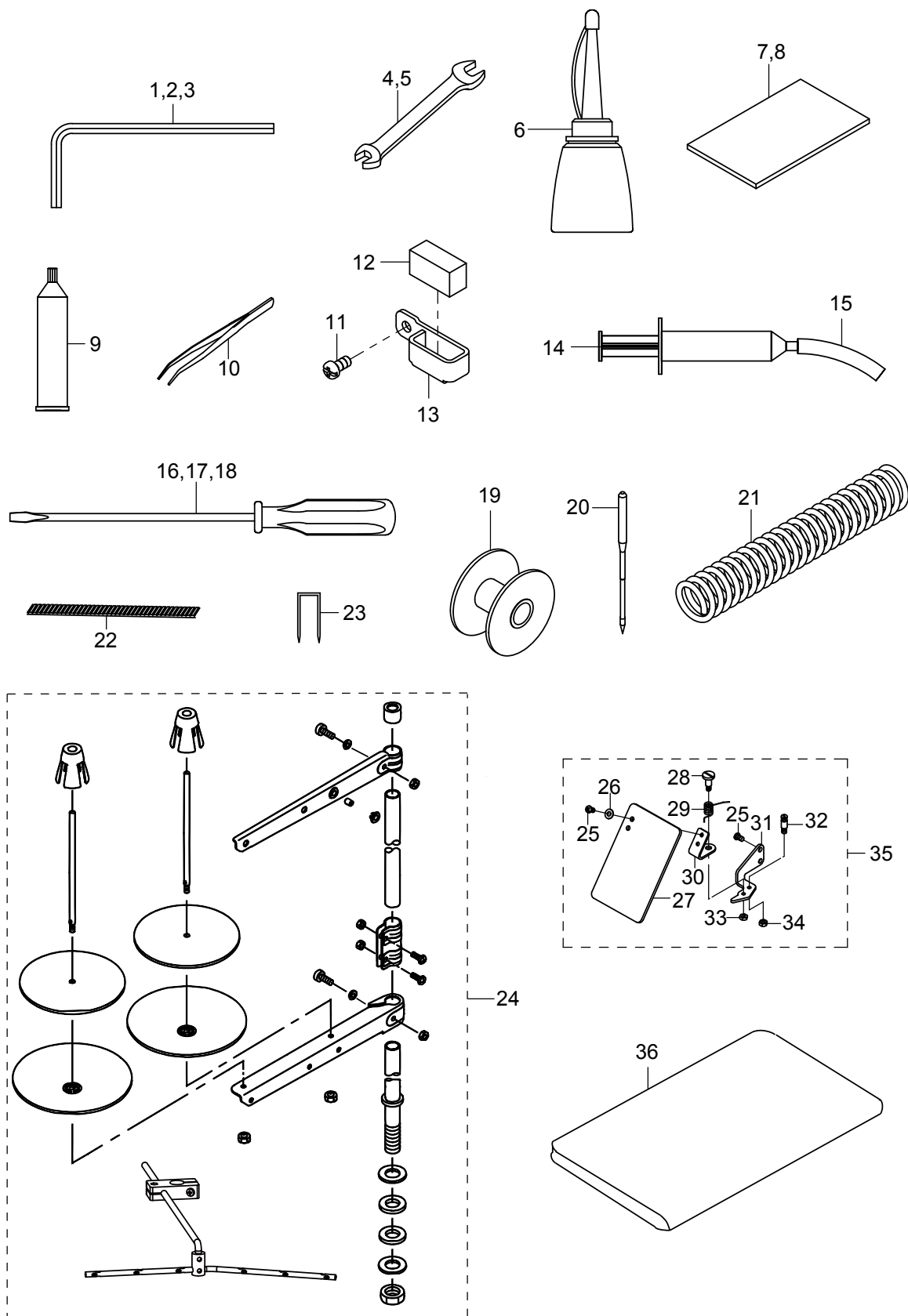

附件部件

ACCESSORIES COMPONENTS

序号 No.	件号 Part No.	名称	DESCRIPTION	数量 Qty
1	10009685	内六角扳手 3	HEXAGONAL WRENCH 3	1
2	10009687	内六角扳手 4	HEXAGONAL WRENCH 4	1
3	10009689	内六角扳手 5	HEXAGONAL WRENCH 5	1
4	10003369	呆扳手 8×10	WRENCH 8×10	1
5	10003368	呆扳手 9×11	WRENCH 9×11	1
6	10005356	油壶	OLI CAN	1
7	10032424	5770A-3020使用说明书	INSTRUCTION MANUAL	1
8	10032425	5770A-3020零件手册	PARTS BOOK	1
9	20009052	油脂软盒_加油脂后	OIL BOX	1
10	10004247	镊子组件	TWEEZERS	1
11	10011143	螺钉 SM9/64"×40 L=7	SCREW SM9/64"×40 L=7	1
12	10000396	硅油毡	FELT	1
13	10000398	硅油板	THREAD GUIDE	1
14	10003361	注射器	INJECTOR	1
15	10007800	油管 φ3×φ5	TUBE φ3×φ5	60
16	10010994	大螺丝刀	SCREW DRIVER LARGE	1
17	10010995	中螺丝刀	SCREW DRIVER MIDDLE	1
18	10013185	小螺丝刀	SCREW DRIVER SMALL	1
19	10000649	梭心	BOBBIN	2
20	10038680	机针 DP×5 10#	NEEDLE DP×5 10#	10
21	60000115	吹气管	INPUT TUBE	1
22	10038527	开口橡胶同步带B	SYNCHRONOUS BELT B	10000
23	10011754	电线固定钉	NAIL	1
24	10007130	二线线架部件	THREAD STAND	1
25	10011570	螺钉 SM11/64"×40 L=7	SCREW SM11/64"×40 L=7	4
26	10011680	垫圈 4.6×9.7×0.8	WASHER 4.6×9.7×0.8	2
27	10011636	安全板	SAFETY PLATE	1
28	10011677	螺钉轴	HINGE SCREW	1
29	10011678	弹簧	SPRING	1
30	10011684	安全板架组件	SAFETY PLATE INSTALLING PLATE B	1
31	10011632	安全板座	SAFETY PLATE INSTALLING PLATE A	1
32	10011633	销钉	SCREW PIN	1
33	10010370	螺母 SM11/64"×40	NUT SM11/64"×40	1
34	10011682	螺母 SM3/16"×28	NUT SM3/16"×28	1
35	20004358	眼睛防护罩组件	SAFETY PLATE ASM	(1)
36	10000404	机头罩	MACHINE HEAD COVER	1